



vo-CE 4.0

USER MANUAL

Itworks srl
<http://www.it-works.it/vo-CE>
User Manual Released November 2012

Copyright 2012

Index

Index	1
1 Introduction	5
1.1 Overview	5
1.1.1 vo-CE PC version	5
1.2 Software features	6
1.3 "Online" configuration	7
1.5 The speech mode	8
1.6 Properly use of BNF rule and Regular Expressions	9
1.7 New features	12
1.7.1 Features from vo-CE 3.5	12
2 How it works	15
2.1 Setting up	15
2.2 Configuration	15
2.3 User Interfaces	16
3 Differences from the version 2.3	18
3.1 Workflow differences	18
3.2 New commands:	18
4 vo-CE tools	20
4.1 Software overview	20
4.2 Manager	22

Create new project	22
Open an existing project	23
Edit vo-CE.ini parameters.....	24
4.3 INTERFACE.....	44
Server TCP/IP - Connect vo-CE to the "Interface"	45
Server RDP - Connect vo-CE to the "Interface"	45
Server HTTP - Connect vo-CE to the "Interface"	46
Run Telnet.....	46
Run vo-CE PC & Telnet.....	47
4.4 LOG	48
Open Log	50
Simulation	51
On Line.....	52
Log Acquire	54
4.5 TRAINING.....	55
Profile Management	55
Server	56
4.5 SUPERVISOR	57
Messenger.....	57
Audio Samples	58
APPENDICES	59
A Escapes sequences strings.....	60

B	Server side commands	62
	General syntax	62
	Volume setting command:.....	62
	Rate setting command:	63
	Start to recognize commands:	63
	Stop to recognize commands:	63
	Grammar switching:.....	64
	Profile changing:.....	64
	vo-CE.ini file changing:.....	64
	Quit vo-CE:.....	65
	Confidence threshold changing:.....	65
	Send a message without modifying the repeat string	65
	Check command	65
	Disable the Check	66
	Load a Regular Expression	66
	Change a Regular Expression	66
	Activate a new syntactic rule	66
	Modifying a parameter in the vo-CE ini file:	66
	Training session:	67
	REPEATING ALL THE PRONOUNCED NUMBERS	67
C	licensing site	68
D.	Vo-CE downloading site.....	72

E GLOSSARY74

1 INTRODUCTION

1.1 Overview

vo-CE is the new voice picking software developed by [Itworks srl](#) for Windows CE.Net operating system (4.2 or 5.0).

With vo-CE, a WMS system working with normal hand held devices (with a CE.NET operating system) can be easily and quickly equipped with automatic speech recognition (ASR) and text to speech (TTS) engines.

Itworks, after a careful software selection, has chosen Nuance speech engines to power its vo-CE software.

[Nuance](#) is the leading provider of speech and imaging solutions for businesses and consumers around the world.

vo-CE doesn't need proprietary hardware. This means that potentially each .NET device is vo-CE ready or, at least, vo-CE compatible. In fact, one of the main important distinctive features of vo-CE software application is the synergy of different technologies of data capture: laser scanning (barcode, rfid, imager), data entry with keyboard and voice.

vo-CE has been designed and engineered in order to be immediately integrated into WMS or ERP systems, without any additional middleware software, however if required by the IT Department, vo-CE is compatible with a middleware application.

Also logistics operators recognize vo-CE one of the most user-friendly and efficient tools to manage warehousing procedures. They are able to continue working in the way they were used to, improving efficiency very quickly.

1.1.1 vo-CE PC version

All instructions and procedures in this manual are related to vo-CE for CE devices, but they are also absolutely valid for vo-CE for PC.

1.2 Software features

vo-CE software is powered by two **Nuance** speech engines, the TTS and the ASR.

Together with vo-CE application, the user gets the vo-CE Tools software, which was designed by Itworks to configure and optimize the performance of the voice system.

The ASR engine allows to:

- encode vocal commands;
- set up a particular feedback when a specific command has been recognized;
- change the software default settings;
- download from FTP sites.

The TTS engine allows to:

- select the speed rate and of the speech output volume;
- repet - on operator request – of the last phrase reproduced by the speech engine.

vo-CE is a "speaker independent software", it means that it is able to recognize the voice commands of any user without associating the operator and with the speech engine.

However some particular logistic environments need a preliminary software customization in order to help the speaker recognition to do its best.

vo-CE also requires a professional headset with the ambient noise cancellation function.

If the hand held devices provider doesn't have their own headset, Itworks can suggest a highly performant one produced by a leading international group.

1.3 "Online" configuration

vo-CE can be used as a standalone application or can be integrated in a existing application with the .NET Software Development Kit.

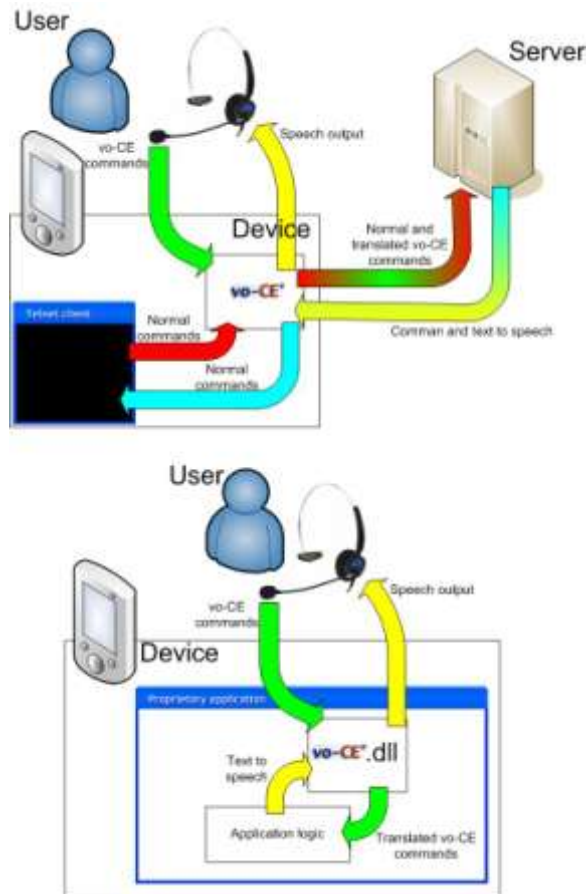

vo-CE software is a multi-thread application running on the mobile device only.

The first thread has the task to create a bridge from the emulation software to the server, using two sockets: the first one from the emulation software to vo-CE (device's IP, local port), the second from vo-CE to the server (server's IP, remote port).

When the connections are on, vo-CE begins to analyze all the data streaming between the server and the emulation software, looking for vo-CE TAGs.

vo-CE TAGs are common strings between two sequences of characters. They contain text to speech or setting commands (e.g. speech rate level, speech volume, tone, etc).

The second thread recognizes vocal commands, encodes them and sends them to the keyboard buffer.

vo-CE is constructed as a .NET DLL that can be embedded in any .NET application that works on a device. This permits to use every vo-CE feature in a custom application and allows full flexibility of its use. vo-CE comes with a complete [SDK documentation](#).

1.5 The speech mode

vo-CE software is powered by Nuance engines that can be used either in “speech independent” or “dependent” mode. The independent one allows the operator to start using vo-CE without any additional activities and is the best and the fastest way to use vo-CE.

However if the “speech dependent” mode is chosen, the performance is not reduced. In fact, vo-CE Tools suite contains some applications to customize the ASR engine. The first one is the “Training” application of vo-CE Tools which is able to process the files recorded by the vo-CE trainer; the second one is used to register voice samples on the client.

A user profile can be created without the “Training” application, simply using a server command \$TRAIB\$ (for information on this command, see the appendix D called “Server commands”).

A training session doesn't need that the user records each word, but only the less-confidence ones. For a better training it is possible to perform more than one recording loop, the application trainer will produce word samples for each loop. During the creation of the trained grammar, “Training” will merge the same word samples to optimize the training performances.

Training procedure gives better results if it is performed with a grammar based on a FULL DAT file (see *chapter 4 for more details*). User profiles, dictionaries and trained grammar increase recognition confidence values and decrease mistakes.

In order to start the training session, the users need to get the connection between the device and the “Training”, that guides the users through the speech samples recording, by scrolling the list of commands.

Once the training is over, vo-CE creates the user profile and the dictionary on the device, in the working directory.

vo-CE will also transfer the created user profile to the FTP site.

1.6 Properly use of BNF rule and Regular Expressions.

With vo-CE 4.0, it is possible to use a vocabulary BNF file for the Speech Recognition, but it must be compiled into an LCF file to optimize the performance; vo-CE 2.0 could only use the BNF file and vo-CE 1.3 could only use a grammar file.

vo-CE.ini file has a new parameter that allows the use of LCF file:

CONTEXTNAME=<the name of the LCF file>.

A BNF file can be compiled by vo-CE Tools or by a web application [Vocegrammar](#)



The screenshot shows the Vocegrammar web application interface. At the top, there is a navigation menu with links for HOME, CASE STUDIES, PARTNERS, SUPPORT, and MAP. The main content area is titled "Grammar creation steps:" and lists three steps: "Select a language matching the language of the BNF file", "Load the BNF file from disk", and "Create the grammar pressing the Create button". Below this, there is a "Grammar Creation Form" with a "Select Language" dropdown menu set to "Dutch The Netherlands", a "Load BNF File" input field with a "Browse..." button, and a "Create Grammar" button labeled "Create".

The web application to compile the BNF: choose the language of your BNF, upload it and compile it.

The best way to set up vo-CE is to use a BNF rule that is as general as possible and several regular expressions. As example we'll use the standard BNF for British English

```
#BNF+EM V1.0;

!grammar "VOCE";
!language "British English";
!start <start>;

<start>: !repeat(<DIGIT>,1,4)!optional(OK) | <command> | <special>;

<DIGIT>:
1
|2
|3
|4
|5
|6
|7
|8
|9
|0;

<command>:
OK
|CONFIRM
|DELETE
|CANCEL
|NEXT
|BACK
|SKIP
|END
;

<special>:
RAISEUP
|RAISEDOWN
|ACCELERATE
|SLOWDOWN
|YES
|NO
|MICROPHONE
|REPEAT
|DICTIONARY
|ACTIVATE
|DISABLE
;
```

An example of a BNF file:

Using this BNF file, the engine is able to recognize numbers from 0 to 9999 followed by a confirmation (usually, but not always, by the word OK), the directive `!repeat(X,Y,Z)` means that the group of words X can be repeated from Y to Z times, or can recognize the words contained in the group `<command>` and in the group `<special>`.

The file is constructed with the Backus-Naur Form syntax. The only rule to activate it is `<start>`.

Note that the character "`|`" indicates "or" and the character "`;`" indicates the end of an instruction.

Using regular expression you can control what is recognized by vo-CE.

Normally the regular expressions are listed in the vo-ce.ini with a name and with the command REGEF to change to another regex.

That way makes vo-CE faster and more reactive, because to change a regular expression is way faster than to change a rule of the engine.

A regular expression, often called a **pattern**, is an expression that describes a set of strings. They are usually used to give a concise description of a set, without having to list all elements.

For example, the set containing the three strings "Handel", "Händel", and "Haendel" can be described by the pattern H(ä | ae?)ndel (or alternatively, it is said that the pattern *matches* each of the three strings).

Normally, if there is any regex that matches a particular set of strings, then there is an infinite number of such expressions.

Simple example of REGEX:

```
\A\d{1,2}OK\z|NEXT
```

Explanation:

\A – beginning of a sentence

\d – one digit (0-9)

{x,y} – repetition of the previous character from x to y times

\z – end of a sentence

| - OR clause

So the previous REGEX will match any sentence that begins with one or two digits followed by OK, or will match the word NEXT.

vo-CE Tools provides a section to create and try regular expressions.

1.7 New features

The new release of vo-CE 4.0 adds a new major feature: the Remote Desktop Protocol compatibility.

Now vo-CE can communicate with applications that work with RDP connection between the device and a server. The compatibility is granted by a DLL (VOCERDP.DLL) that must be integrated in the server side application. The DLL is written in evc4++ and can be use by .NET applications and by PowerBuilder applications.

Together with vo-CE 4.0, the 2.0 version of vo-CE Tools 2.0 has also been released. Besides the compatibility with vo-CE 4.0, vo-CE Tools 2.0 is able to use the HTTP and RDP to perform a vo-CE demo.

1.7.1 Features from vo-CE 3.5

The release, vo-CE 3.5, has the new Nuance Vocon ASR engine v3.2, with improved performance, new commands and features.

It makes use of the advantages of the first release of vo-CE 2.0 in a new platform.

These are the features of vo-CE 2.0 that have been rewritten and improved in vo-CE 3.5

- 1) VOCEDLL.DLL: this library created in vb.net 2008 is the main interface used by the software developers for their own applications in vb.net and in c# for compact framework. Itworks is ready to share source codes and documentation for developers (for further info please contact: info@it-works.it)
- 2) Custom.dll: this is a plugin that can be created by the user in order to add some functions to vo-CE.exe (printing, rfid reading, etc.). The functions are activated directly from the server with the command \$CUSTOxxxxxxx\$
- 3) Device.dll: this library is specific for single device and it allows to enter, on the server side, with the command \$DEVICxxxxxxx\$ to some functions of the hardware: keyboard blocking/unblocking, monitor switch on/off...
- 4) vo-ce.dll: this library doesn't have a direct access, but it contains the code that manages ASR/TTS/VOIP; this part is written in evc4++ in order to maintain the best performance

There are a lot of new features included in the new release:

1. Use of Regular Expressions

In the best case, vo-CE uses a regular expression to validate what is recognized by the ASR, the ASR uses grammar only with a general RULE and then vo-CE would validate what is recognized with a regular expression.

2. New commands implemented

- a. REGEX, REGEF to change the regular expression
- b. CHECK to validate check digits

3. New recognition engines from Nuance (Vocon 3.2)

4. Use of compiled BNF for better performance

5. Recording audio samples during normal activity of the device (via vo-CE Tools)

6. Sending short messages to be pronounced by the TTS to the device (via vo-CE Tools)

It also maintains all the features of the older version with some improvements

1. New training procedures: automatic and accurate

2. Unicode management: the engine is Unicode, this allows to manage correctly such languages as Russian (already developed)

3. Changing the codepage 5250 for a correct localization of the software

4. Changing all the existing parameters in the ini.file directly from the server

5. FULLDUPLEX: it is possible to have the recognition activity during the TTS activity

6. BEEPWAV: after the recognition activity, the system can reproduce any Wav file in the "vo-CE" folder of the device's flash memory instead of the system's beep. In the configuration file (vo-CE.ini) the "BEEP" parameter must be set to a 1 value while in the "BEEPWAV" parameter you should set only the name of the Wav file as shown:

```
BEEP=1
```

```
BEEPWAV=TestSnd.Wav
```

If the Wav file name is omitted, the system will perform the standard beep after the speech recognition is performed

7. PRYORITY: It is possible to set the application thread priority to optimize operations. By default this value is set to the maximum value (150)

8. REMAPFIRSTMATCH: If this parameter has the value of 1, the word is remapped only the first time it occurs in the sentence.

The system is also organized to have FineTuning: to modify the parameters of the recognition engine in order to optimize the performances.

2 HOW IT WORKS

2.1 Setting up

vo-CE is delivered in a .ZIP file (Example: vo-CE_ITI_4000.zip).

In order to install vo-CE, you need to extract the .zip file and copy the folder vo-CE in the flash directory of the device (for example via Active Sync or FTP). Note: if the device has a Flash memory, and you want to install vo-CE in a different path, you need to create a vo-CE directory in the Flash memory with the following files: vo-CE.ini, grammars and BNF files. If the device doesn't have the Flash memory you need to install vo-CE in the main root.

Create a shortcut icon linked to the vo-CE.exe file in the path "flash memory"\speech \components and copy the icon on the desktop.

To start vo-CE, double click the shortcut icon linked to the vo-CE.exe file. At the first start you will get a text box ERROR LICENSING, as you need to have a valid Licence in order to start working with vo-CE. In order to get a licence from your licence pools please see appendix C; to get a Demo Licence go to the [DEMO licence site](#).

2.2 Configuration

Before starting vo-CE, some parameters have to be set, such as the Server's address IP, the remote port and the local port. It is important to configure the Emulation Software to connect it to device address on the vo-CE's local port. It's recommended not to use the loopback address but the effective device's IP address. See "Change Setting for vo-CE" for more details on configuration.

You can also install vo-CE in different languages on the same device, executing the right .cab file for the selected language.

To change the working language you must use the `$NWIN\ini_name.ini$` server command.

2.3 User Interfaces



Figure 1



Figure 2

To start vo-CE double-click on the rhomboid icon ( vo-ce.exe).

vo-CE copies all files from "flash memory"\vo-CE (flash memory is the name of the ROM storage memory) into its starting folder.

The pictures above show the following objects:

- SHOW: press this button to expand the windows view (as show on Figure 2).
- START: start the (ASR and TTS) engines and socket.
- ASR: start the recognition activity.
- STOP: stop the recognition activity.
- QUIT: quit.
- AS400, HTTP: the protocol that is used.
- KEYBUFF: indicates if key buffer option is used.
- CONFIDENCE: the recognize quality threshold. Each recognition is associated with a confidence value, if it is lower than the threshold, the command is rejected.
- HOST: the server 's IP address to which vo-CE is connected.
- REMOTE PORT: the server's remote port to which vo-CE is connected.
- LOCAL PORT: the local port used by vo-CE for the connection.
- Get ID: press this button to see the Machine ID and to insert the license.

- Recognized commands list: recognized commands sorted by confidence value. Only the commands with the highest confidence (if higher than the threshold) are accepted.
- Text to speech: press SPEAK to make vo-CE pronounce the text to speech inserted in the box. Note that is very helpful to start the TTS engine and to have a fast working test.
- License state: this field indicates if vo-CE is licensed or not.
- State: the recognition state of vo-CE, i.e. "speech detected" or " waiting for speech"
- Condition: this field indicates the recognition condition. For example "Signal too Loud" means that the volume is too high and vo-CE might have problems to recognize the command in the right way.

When starting vo-CE, the ASR engine is deactivated.

The configuration .INI file, has a specific threshold, STRTED, that can either allow or deny the ASR engine activity .

With STRTED = 0, the ASR engine activity starts only with the server command @\$START\$#. Note that it is still possible to manually start the ASR activity by pressing CLOSE/START/ASR in sequence.

With STRTED=1, the ASR engine activity starts manually, by pressing CLOSE/START/ASR in sequence, or automatically when the emulation software tries to connect to vo-CE.

After the launch of the vo-CE application, it is possible to start the emulation software.

Configure it at the device's IP address - vo-CE local port. vo-CE will run in background during the working session.

3 DIFFERENCES FROM THE VERSION 2.3

3.1 Workflow differences

There are some differences between the 2.3 version of vo-CE and the 4.0 version.

Use of regular expression:

The best way to use vo-CE is to implement a general RULE and use regular expressions to validate what is recognized according to your needs. But it is still possible to use the command RULE to change the RULE of the engine as in vo-CE 2.3. There is another feature called "Compatibility Mode", which means that you can use the efficiency of regular expressions without changing anything on the server-side: if the parameter RULETOREGEX is set for every command, the RULE sent to voce will be considered as a "change regex" command (REGEX) and a regular expression named as the RULE will be loaded. These options are included into every version starting from vo-CE 3.0.

Use of compiled BNF:

vo-CE 4.0 uses compiled BNF files (LCF files) that are compiled by vo-CE Tools or by our dedicated [site](#).

3.2 New commands:

CHECK – syntax \$CHECK<value> | <type> | <error message> | <minor option> | <question>\$ vo-CE performs a local check, i.e. for the check digit, without sending the data to the server. To allow the best performance of the <value> recognition, vo-CE assigns a confidence boost to that value; the boost is determined by the parameter BOOSTVALUE (default 1000).

<value> value to check.

<type> can be:

0 – User must say EXACTLY the <value> that is requested. Parameters <minor option> and <question> are not necessary.

1 – User can say a number that is smaller or equal to the <value>, but if it is smaller than the <value>, User must confirm that number. vo-CE will ask a <question>.

2 - User can say a number that is smaller or equal to the <value>, no confirmation is needed.

<error message> is the message that will be sent by vo-CE, if the User says a wrong number.

<minor option> can be:

0 – ask confirmation with a <question>, the User must reply with Yes or No.

1 - ask confirmation with a <question>, the User must repeat the number that has been just said.

<question> is the question asked by vo-CE when <type> is 1 or 2.

UNCHK – syntax \$UNCHK\$ Disable the previous CHECK command

REGEX – syntax \$REGEX<regular expression>\$ loads the given regular expression

<regular expression> is the regular expression that will be loaded by vo-CE (See chapter XXX)

REGEF – syntax \$REGEF<regular expression name>\$ loads a regex with the selected name

<regular expression name> is the name of the regular expression that will be activated, that regular expression must be included into the vo-ce.ini file under the section [REGEX].

4 VO-CE TOOLS

4.1 Software overview

This software is designed not only for vo-CE parameters configuration, it is also a practical tool for interacting with the device during the operator's activities.

It is divided into five applications:

- Manager
- Interface
- Log
- Training
- Supervisor

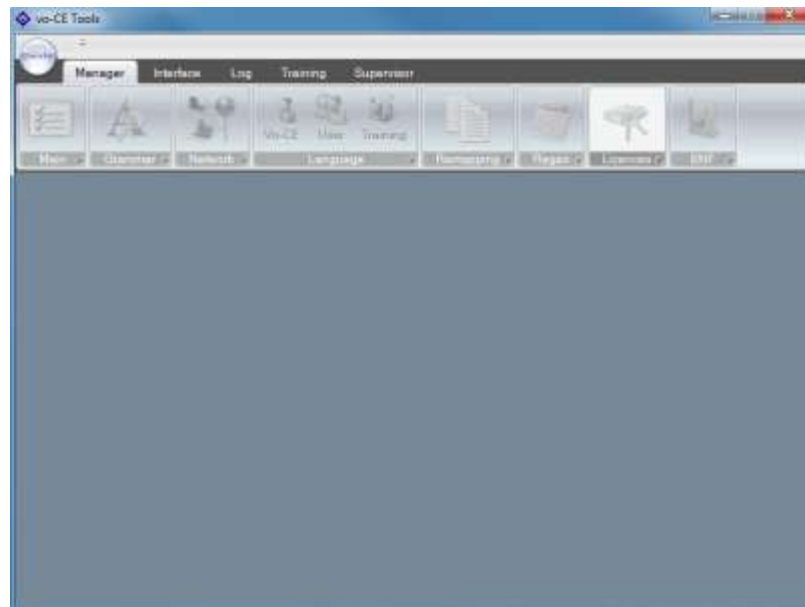

- “Manager” allows you to set all the parameters that will be used by vo-CE for its operation. It also allows you to define the grammar and create the compiled file.
- “Interface” is a WMS prototype to test the vo-CE features. Using “Interface” you can appreciate the performance of voice picking, without modifying the current WMS. Supports TCP/IP, HTTP and RDP protocols.
- The “Log” application allows you to analyze the log file created by the device. It also allows to observe in real time the log created during the activity or save it directly to disk.

- In the “Training” application you can define a project profile and specify the words to be trained by a given operator.
- “Supervisor” allows you to send messages to the operator during his work and also enables the device to save voice samples.

4.2 Manager

In the “Manager” application you can open or create a vo-CE project. Press the vo-CE Tools button and choose the desired task.

Create new project.

To create a new project:

1. Click the vo-CE Tools button
2. Select New
3. Select Project Language
4. Write Project Name
5. Click the Create button

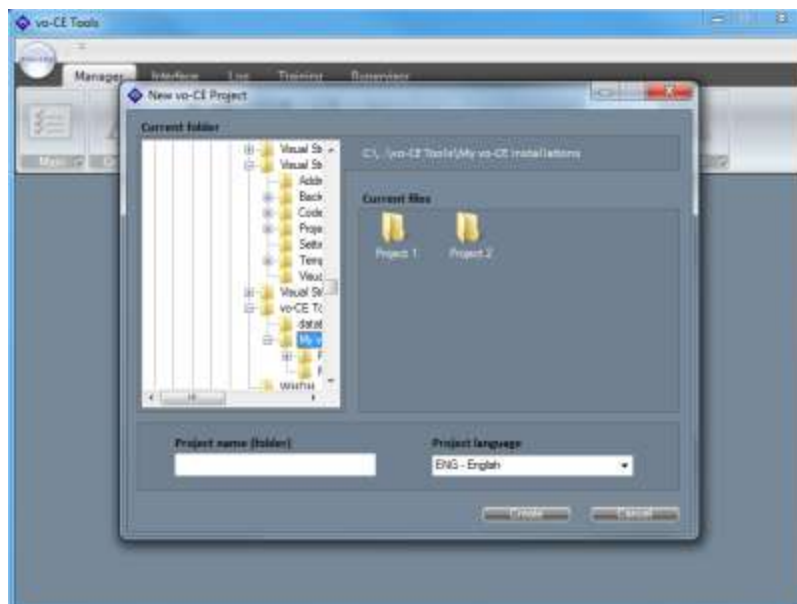
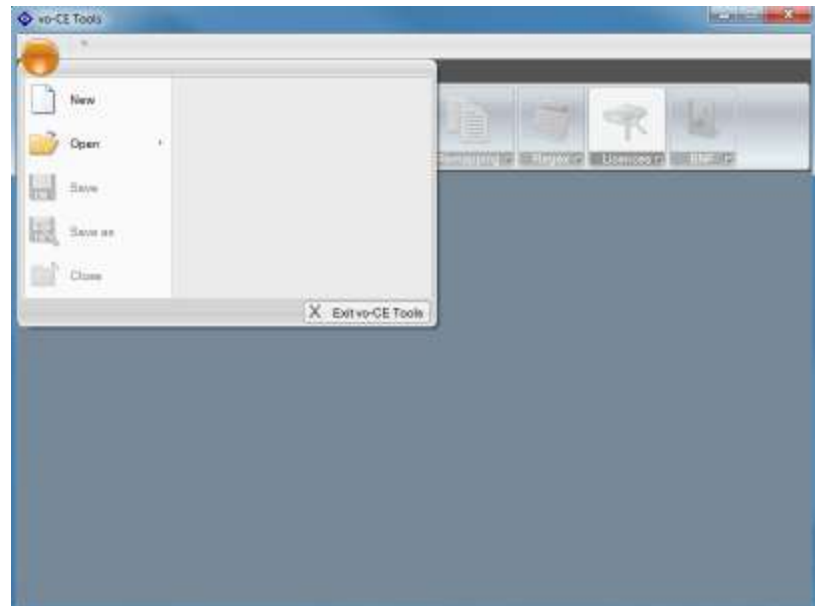

Pressing “Create” the desired folder will be generated in the specified location containing the files of the project default (for example, for the English language, the default files are vo-CE.ini, default_eng.bnf and default_eng.lcf).

The default directory of vo-CE project is Documents\vo-CE Tools\My vo-CE installations

Open an existing project.

To open an existing project:

1. Click the vo-CE Tools button
2. Select Open
3. Double-click the desired vo-CE.ini file

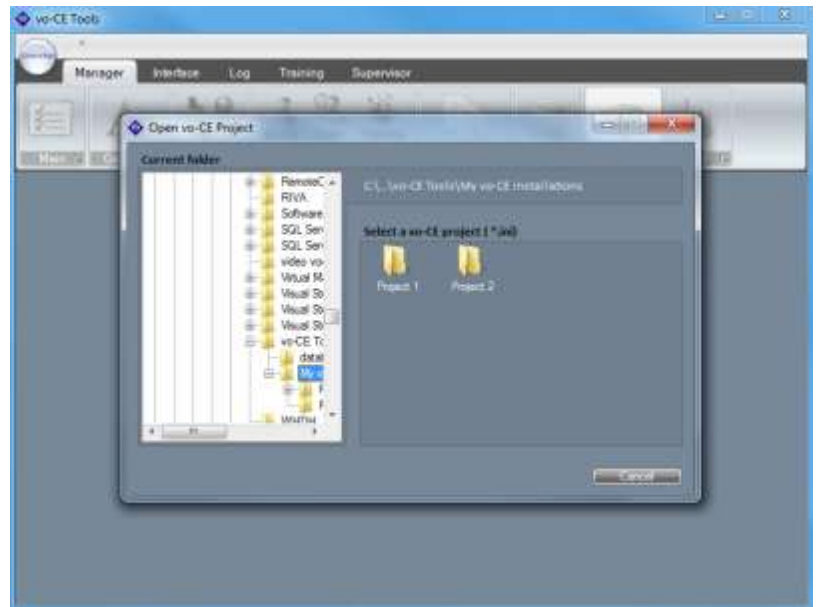

Edit vo-CE.ini parameters

In the management section, you can set vo-CE parameters. These are divided into groups which correspond the following subsections:

- Main
- Grammar
- Network
- Language
- Remapping
- Regex
- Licenses
- BNF

You can set the value of each characteristic. Moving the mouse to the description you may notice the name of the ini file parameter which the field belongs to.

Main

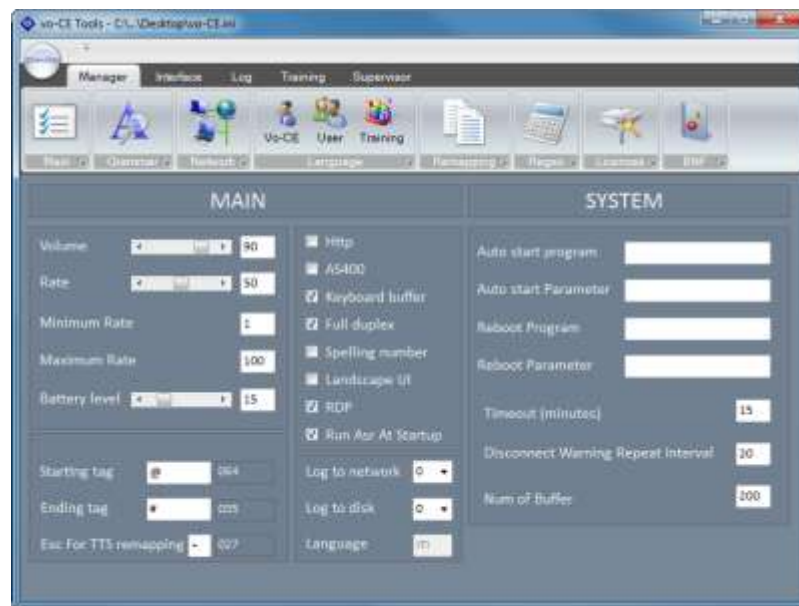

This section allows you to configure parameters for general characteristics.

Below there are the parameters that can be modified using the "Main" subsection.

- Volume (VOLUME):
is the speech volume level.
NOTE: this value can be changed by the user's commands or by the server commands.

- Rate (RATE):
is the speed of TTS.
NOTE: this value can be changed by the user's commands or by the server commands.

- Minimum Rate (RATEMINLEVEL):
is the minimum speed of TTS.
NOTE: this value can be changed by the user's commands or by the server commands.

- Maximum Rate (RATEMAXLEVEL):
is the maximum speed of TTS.
NOTE: this value can be changed by the users command's or by the server commands.

- Battery Level (BATTERYLEVEL):
the battery charge level threshold (expressed in percentage). If the battery charge level is lower than that, vo-CE alerts the user with a warning message and repeats it every 5% of the battery loss.

- HTTP (HTTP):
indicates if vo-CE uses the HTTP protocol. Assign "1" as the value to indicate true, "0" to indicate false.

- AS400 (EBCDIC):
indicates if vo-CE uses the EBCDIC protocol. Assign "1" as the value to indicate true, "0" to indicate false".

- Keyboard buffer (KEYBBUF):
 - it indicates if vo-CE sends the recognized command (or its encoding) to the keyboard buffer. Assign "1" as the value to indicate true, "0" to indicate false.
 - Note: this parameter has always to be True if VT5250 or HTTP protocols are used.

- Full duplex (FULLDUPLEX):
 - o if set to 1, enables the ASR even when the TTS is speaking.

- Spelling number (SPELLINGNUMBER):
 - o if set to 1, the TTS will say all the number as separate digits.

- Landscape user interface (LANDSCAPE):
 - o vo-CE control panel can be set horizontally.

- Remote Desktop (RDP):
 - o indicates if vo-CE uses the Remote Desktop Protocol. Assign "1" as the value to indicate true, "0" to indicate false.

- Run Asr At Startup (RUNASRATSTARTUP):
 - o when the RDP parameter is enabled set this parameter to "1" to start automatically the ASR.

- Log to network (TCPLOG):
 - o if set to 1, enables the remote logging.

- Log to disk (LOGTOFILE):
 - o if set to 1, enables the feature of saving the a log file on the device.

- Language (TLW):
 - o the language of the vo--CE setup.

- Starting tag (STARTSPEAK):
 - o the string that makes vo-CE say the words that come afterwards, until it the ending tag.

- Ending tag (STOPSPEAK):
 - o the string that makes vo-CE stop speaking.

- Esc for TTS remapping (TTSESC):
 - o a special character sent from the Server to vo-CE to introduce a TTS command (such as a rate changing).
 - i.e. if TTSESC is "§" then the command to change the volume will be: "§\vol=90\"

- Auto start program (SHELLPROGRAM):
 - o linking a path to the file on the device to this parameter, the application will start automatically starting vo-CE.

- Auto start parameter (SHELLPARAMETER):
 - o with this parameter it is possible, if requested, to transfer parameters and values to the application started with the auto start path.

- Reboot program (WRMPROGRAM):
 - o the device-related program for warmboot.

- Reboot parameter (WRMPARAMETER):
 - o the parameter for the warmboot program.

- Timeout (TIMEOUT):
 - o timeout in minutes for the disconnection.

- Disconnect Warning Repeat Interval (DISCONNECT_REPEAT_TIME):
 - o the interval in seconds which the disconnect message is repeated with.

- Num of Buffer (NUMOFBUFFER):
 - o an advanced parameter that shouldn't be changed. It means the number of audio buffers used for recognition.

Grammar

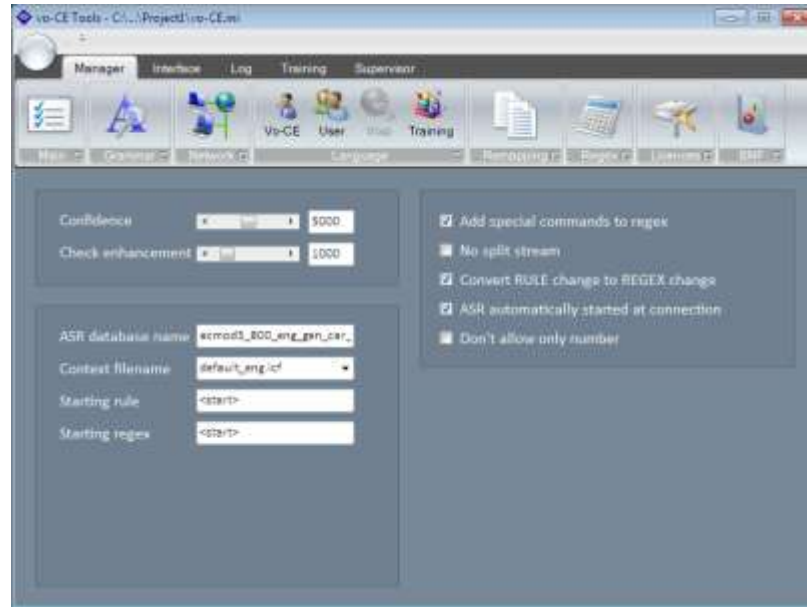

In "Grammar" you can set the parameters for the use of grammar.

Below there are the parameters that can be modified using the "Grammar" subsection.

- Confidence (CONFIDENCE):
 - o The confidence's threshold. vo-CE assigns a Confidence value to each recognized word; if it is lower than threshold, the command is rejected. If you set a high Confidence value, vo-CE will only accept the commands pronounced in an extremely correct way. If low Confidence value is set, it will accept even commands with noise.
- Check enhancement (BONUSVALUE):
 - o The bonus boost to the confidence related to a CHECK command.
- ASR database name (DATFILE):
 - o The database containing all the phonemes of a given language.
- Context filename (CONTEXTNAME):

- The name of the LCF file.
- Starting rule (STARTING RULE):
 - The starting rule of the BNF file.
- Starting regex (STARTING REGEX):
 - The regex that will be loaded at the start.
- Add special commands to regex (REGEXADDSPECIAL):
 - Automatically add special words to every regex.
- No split stream (NOSPLITSTREAM):
 - The text stream to the emulator will not be split.
- Convert a RULE change to a REGEX change (RULETOREGEX):
 - Enables the compatibility mode, so every RULE command is transformed into REGEF command.
- ASR automatically started at the connection (STRTED):
 - If the value is set to "0", you must send the server command \$START\$ to start vo-CE.
- Don't allow only number (DONTALLOWONLYNUMBER)
 - Number pronounced won't be recognized.

Network

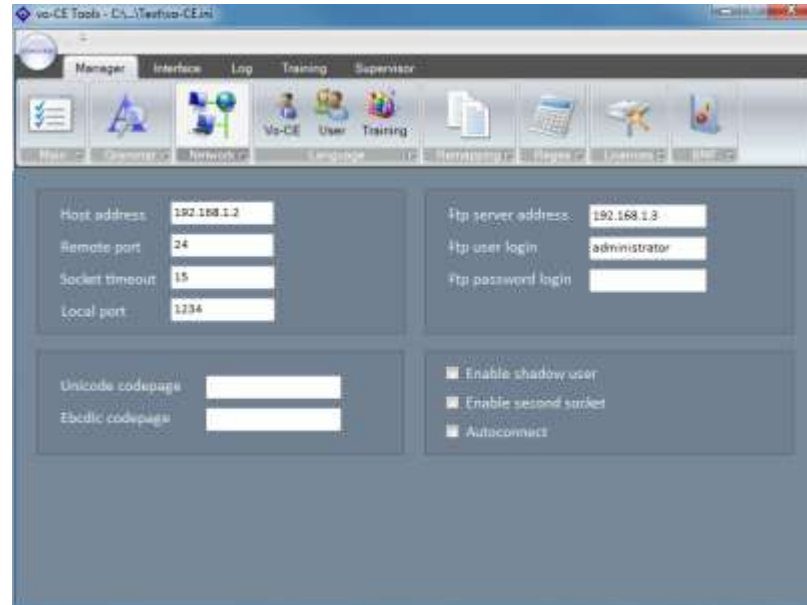

"Network" contains parameters that serve to manage the connection with the server and to enable other network functions.

Below there are the parameters that can be modified using the "Network" subsection.

- Host address (IP):
 - o The IP address of the Server.
- Remote port (REPORT):
 - o The port which the server is listening to.
- Socket timeout (TIMEOUT):
 - o When you set this parameter you define how much time (how many seconds) vo-CE needs to restart after a wi-fi connection failure.
- Local port (LOPORT):
 - o The port used by vo-CE.

- Unicode codepage (CODEPAGE):
 - o The Unicode codepage.
- Ebcddic codepage (E2ATABLE):
 - o The ebcddic codepage.
- Ftp server address (FTPADDR):
 - o After a special command of changing grammar or profile (server command @\$FILE<grammar name>\$#), vo-CE will search the files at the IP address of the FTP server specified for this parameter. Usually the file search is used to upload grammar or profiles.
- Ftp user login (FTPUSR):
 - o Indicates the user name for the FTP login.
- Ftp password login (FTPPWD):
 - o Indicates the password for the FTP login.
- Enable shadow user (SHADOW):
 - o If this value of the mobile device on which vo-CE is already running is "1", it is possible to connect another terminal to the first one using the "LOCALPORT + 1" port. The second terminal will receive the same commands and answers of the first terminal. SHADOW must be also set to 1 in the second terminal.
- Enable second socket (CONTROL):
 - o Enable a control socket for supervisor activities.
- Autoconnect (AUTOCONNECT):
 - o Enable the socket auto-connect.

Language

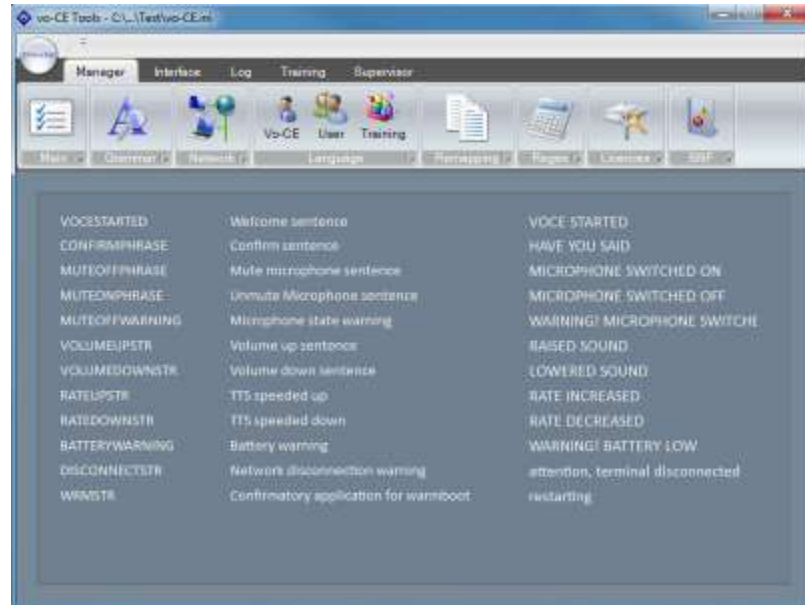

In the "Language" section all the phrases related to communication between vo-CE and the user and vice versa are defined. In subsection "vo-CE" all the sentences spoken by vo-CE are expressed.

Phrases and commands performed by vo-CE:

- VOCESTARTED:
 - o The value of this parameter is the speech output of the vo-CE starting session.
- CONFIRMPHRASE:
 - o the text that is pronounced when vo-CE asks for a confirmation (a "?" added to the command in the Remapping subsection). If the user replies with a REPEATANSWAREYES word, vo-CE accepts the command; if they reply with the REPEATANSARENO word, vo-CE rejects the command.
- MUTEONPHRASE:
 - o The text pronounced when the mute mode is activated. It happens when the operator uses the command defined by MUTESTR parameter.

- MUTEOFFPHRASE:
 - o the text pronounced to notify that the mute mode is off. It happens when the operator uses the command which is defined by MUTESTR parameter and vo-CE is already mute.

- MUTEOFFWARNING:
 - o this value is the speech output when the microphone is off. If the operator continues speaking, vo-CE warns them that the microphone is off.

- VOLUMEUPSTR:
 - o vo-CE notifies with the speech output that volume has been increased.

- VOLUMEDOWNSTR:
 - o vo-CE notifies with this speech output that volume has been decreased.

- RATEUPSTR:
 - o vo-CE notifies with this phrase that speaking speed rate has been increased.

- RATEDOWNSTR:
 - o vo-CE notifies with this phrase that speaking speed rate has been decreased.

- BATTERYWARNING:
 - o vo-CE notifies with this phrase that the battery charge level is lower than the threshold defined by BATTERYLEVEL parameter.

- DISCONNECTSTR:
 - o vo-CE notifies with this phrase that the device is not connected to the server.

- WRMSTR:
 - o vo-CE asks a confirmation for the warm boot

In the field "User" all the commands that the user can send to vo-CE are given.

Phrases and commands performed by the user:

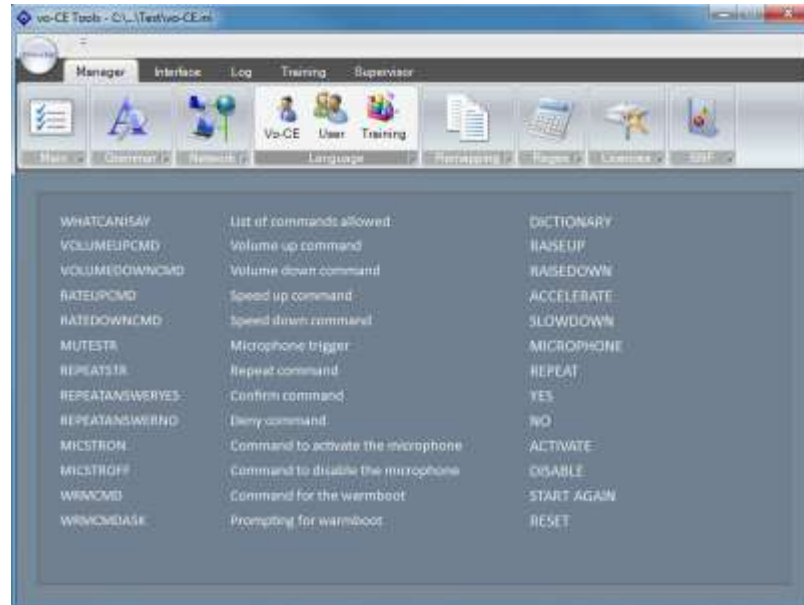

- WHATCANISAY:
 - o when the operator pronounces this phrase, he can listen to all the set commands.
- VOLUMEUPCOMMAND:
 - o a special command to increase the volume.
- VOLUMEDOWNCOMMAND:
 - o a special command to decrease the volume.
- RATEUPCOMMAND:
 - o a special command to increase the speaking rate level.
- RATEDOWNCOMMAND:
 - o a special command to decrease the speaking rate level.
- MUTESTR:
 - o a special command to switch vo-CE to the mute state or reset it to the normal state if it is already mute.

- REPEATSTR:
 - o a special command to ask vo-CE to repeat the last speech output.

- REPEATANSWERYES:
 - o The word to confirm a request (i.e. YES in English)

- REPEATANSWERNNO:
 - o The word to deny a request (i.e. NO in English)

- MICSTRON:
 - o a special command to activate the microphone

- MICSTROFF:
 - o a special command to disable the microphone

- WRMCMD:
 - o a special command that activates the warm boot program

- WRMCMDASK:
 - o question to confirm the warm boot command

In the "Training", there are also some phrases pronounced by vo-CE during the execution of training.

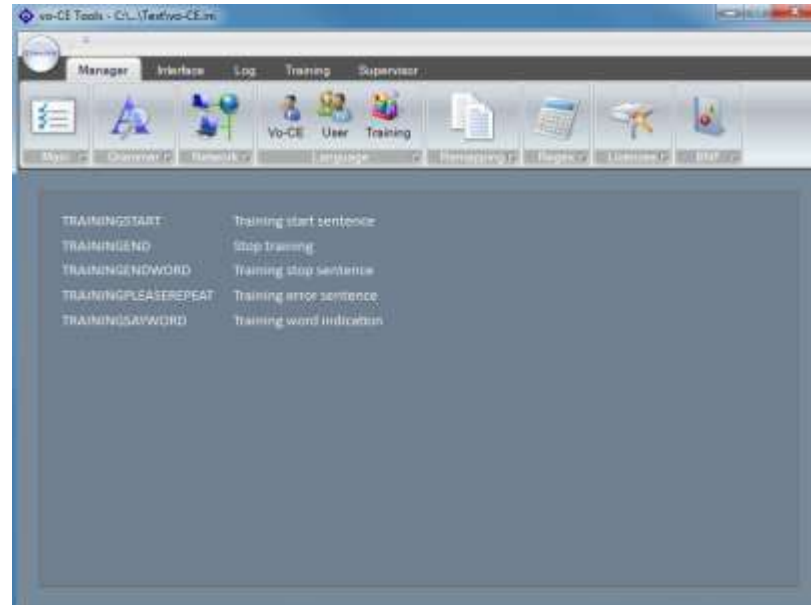

Phrases and commands performed by the vo-CE:

- TRAININGSTART:
 - o the text of this parameter is pronounced at the beginning of the training session.

- TRAININGSAYWORD:
 - o the text of this parameter is pronounced from the system when asking for the command repeating.

- TRAININGPLEASEREPEAT:
 - o the text of this parameter is pronounced by the system when there is a misunderstanding between the word pronounced and the one the system is expecting.

- TRAININGEND:
 - o the text of this parameter is pronounced when the command training is completed.

- TRAININGENDWORD:
 - o the command of this parameter is pronounced when the training session is completed.
Note: the system needs to remap this word and add an ENTER.

Remapping

In the section "Remapping" you can redefine a word using special characters.

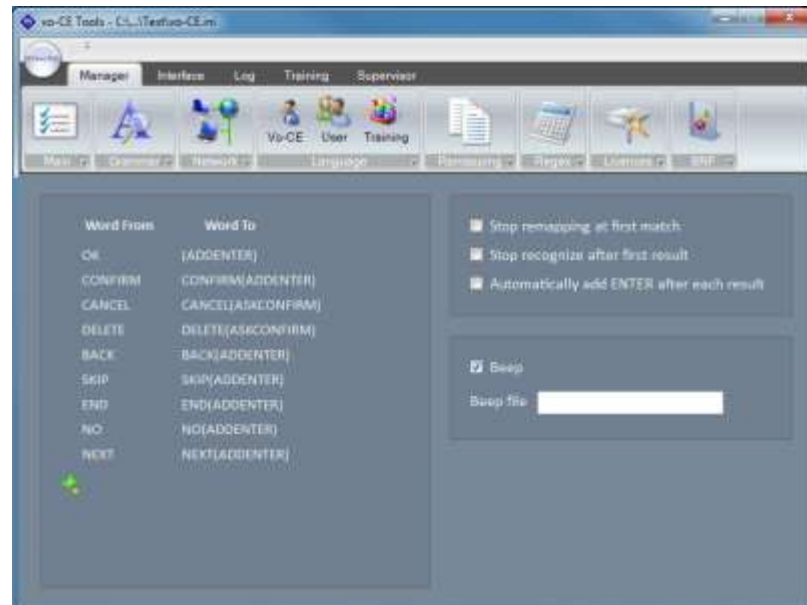

I.e. in the picture below the word OK is remapped as (ADDENTER) which means that instead of the character O and K the character (ENTER) will be sent to the keyboard buffer. Another example is the word CANCEL that is remapped as the character CANCEL (ASKCONFIRM) which means that the character CANCEL will be sent to the keyboard buffer only in case a confirmation is required by vo-CE.

Below there are the parameters that can be modified using the "Remapping" subsection.

- Stop remapping at first match (REMAPFIRSTMATCH):
 - o Normally vo-CE tries to remap every word that it gets from the engine, enabling the vo-CE remap only one time. For example, if you have the word "NEXT" remapped to "OK GO" and the word GO remapped to "CONTINUE", when the user says "NEXT", vo-CE first remaps it to "OK GO" and then "GO" will be remapped to "CONTINUE", so the result is "OK CONTINUE"; with REMAPFIRSTMATCH set to 1 vo-CE will only remap "NEXT" to "OK GO".
- Stop recognizing after the first result (RECOGNIZEONLYFIRSTTUTTERANCE):
 - o Recognize only the first word in the audio buffer

- Automatically add ENTER after each result (AUTOENTER):
 - o it indicates if vo-CE has to add ENTER to each recognized command before resending it. Assign 1 as value to indicate true, 0 to indicate false.



- Beep (BEEP):
 - o it indicates if vo-CE has to make a beep when recognizes a command. Assign 1 as value to indicate true, 0 to indicate false.

- Beep file (BEEPWAV):
 - o The wav file that will be used for the beep sound.

- Word From: to insert the word to remap.
- Word To: to insert the remapped word.

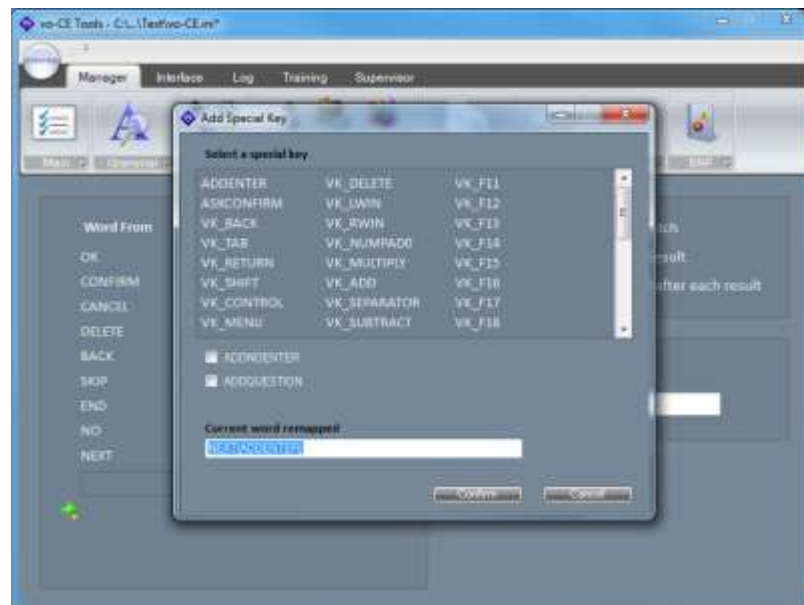
Checking the respective icon "Insert special key"  to choose if add "autoenter", "ask to confirm" or a "no enter" character (as it was explained previously) to the remapped word. You can also add a no-printable key, which will be showed on the field by an understandable code between round brackets.



“New” icon  adds the new parameter to the file vo-CE.ini. Using “Delete” icon  it is possible to delete one or more remapped words. In case the text is changed, a warning icon  appears next to the item under consideration.

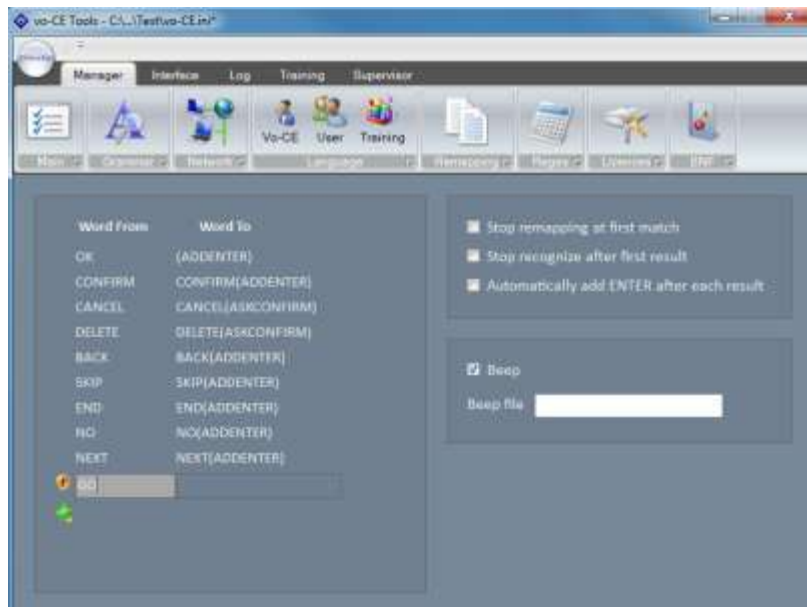



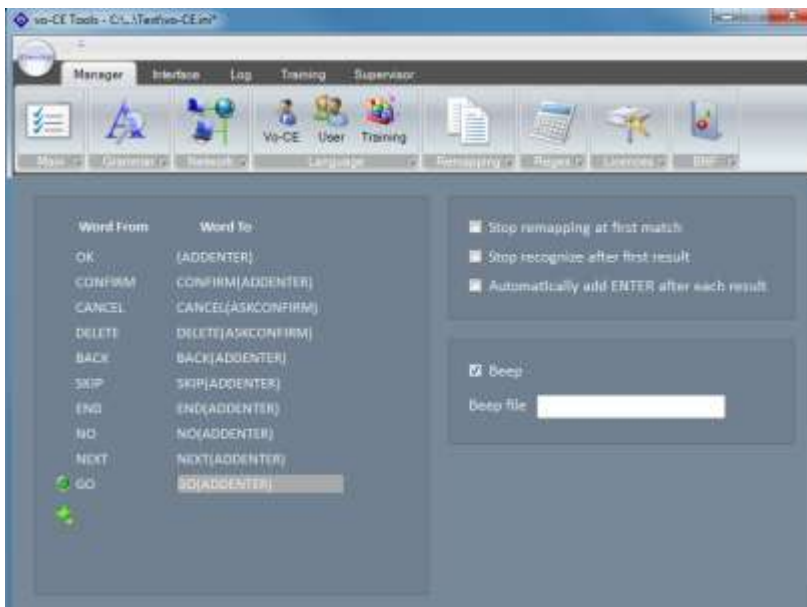

To confirm the change press enter and the confirmation icon  will replace the warning one, confirming that the element has been stored.



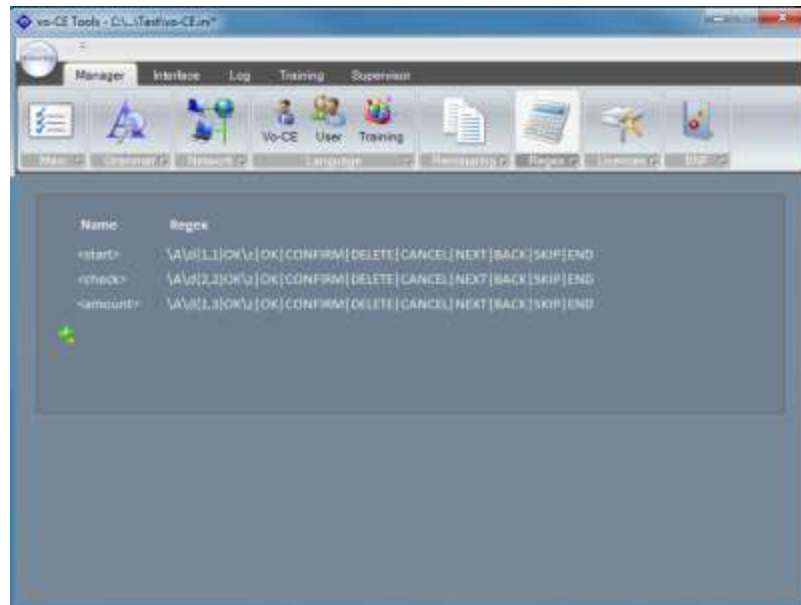

Regex

In the section "Regex" contains the regular expressions included in the vo-CE.ini.

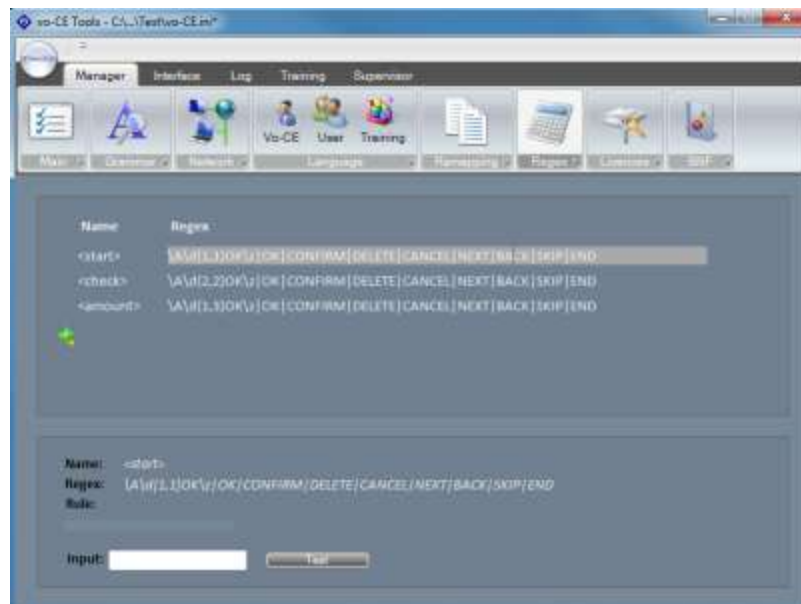

You can add  and delete  some regular expressions and you can also test them. If you click the "Test" icon , a blank box appears where you can insert the text that has to be tested.





As in the previous subsection, when you edit an element, a warning icon  appears next to the item under consideration. To confirm the change press enter and a confirmation icon  will replace the warning one, confirming the storage element.

Licences

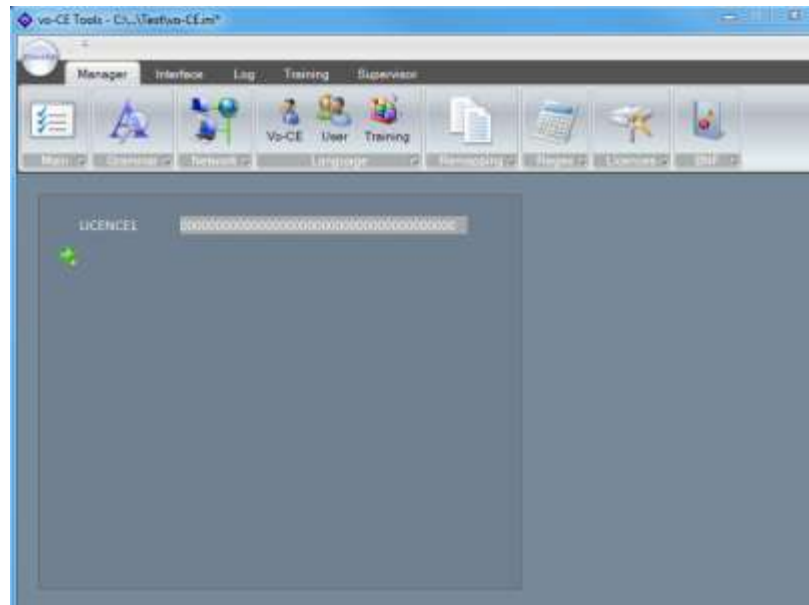
The "Licences" subsection contains the license numbers included into the vo-CE.ini.





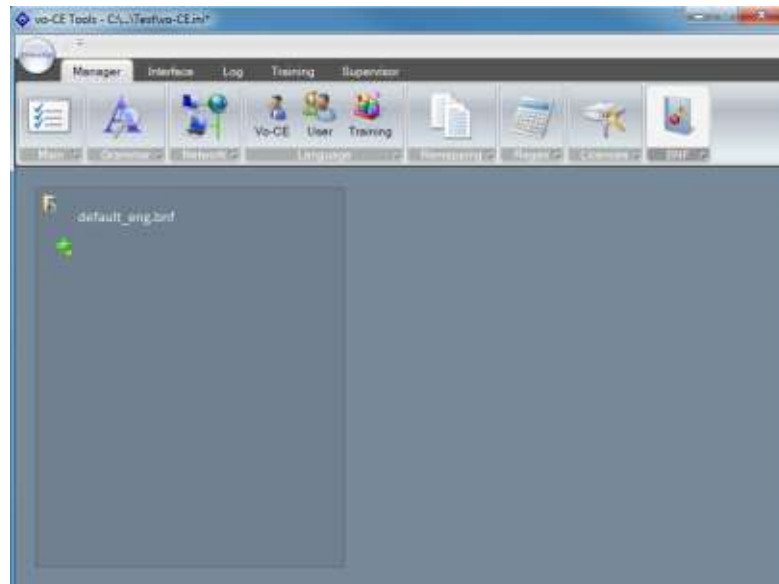

You can add  and remove  some of the license numbers clicking the appropriate icons. The license number must be numeric and contain 39 characters.

BNF

In the subsection “BNF” you can manage the grammar files that are present in the project folder.



Pressing the “New” icon  you can create a new default bnf file and the corresponding compiled file (lcf); you can also remove  the unwanted files. Pressing “Compile” icon  you can obtain the compiled file of the selected bnf. Make sure you are connected to the Internet before you do it. Clicking the “Edit” icon , you can edit the grammar file and save it using the corresponding button.

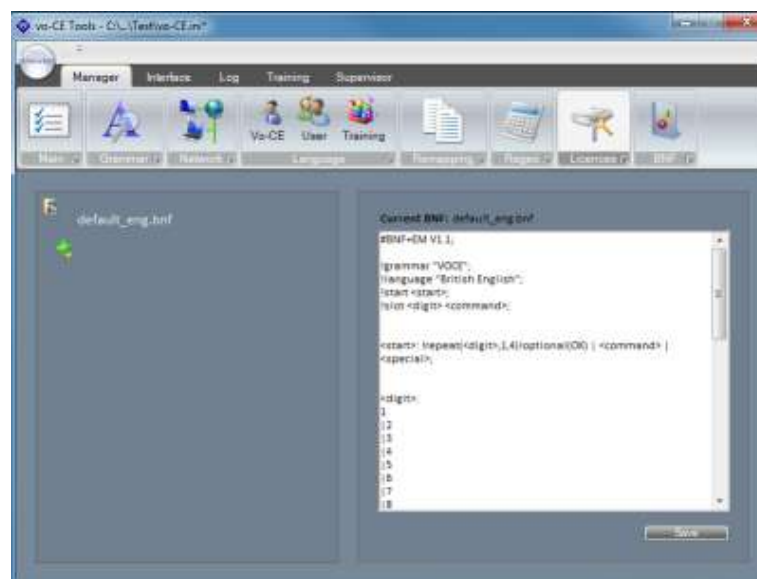



Finally, you can save a bnf file with a specific name by clicking the "Save as" icon .

4.3 INTERFACE

As mentioned above, "Interface" is a WMS prototype used to test the vo-CE features in the WMS.

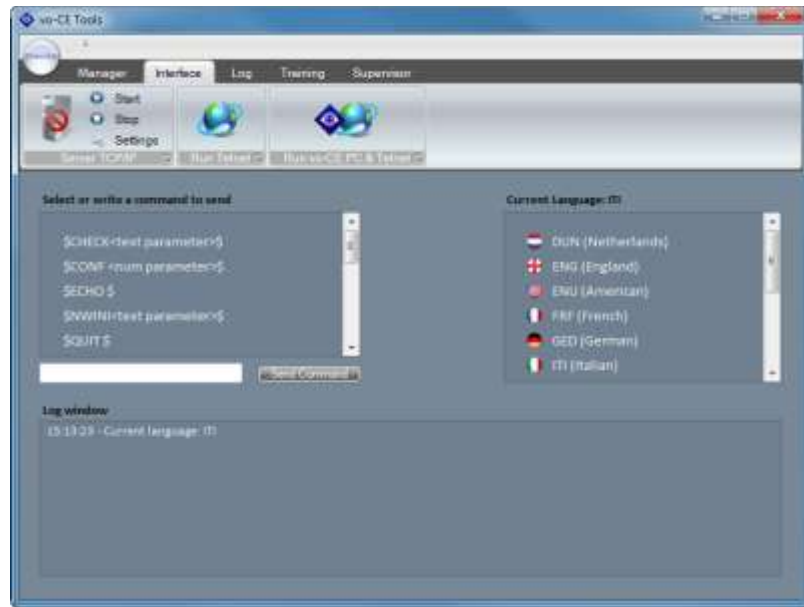
In the "Server" subsection the simulation of a WMS server is implemented. You can start and stop the server and select the protocol to use and sets some parameters.



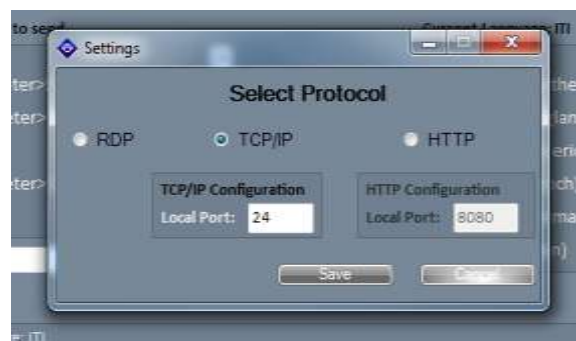

Clicking the  button you open the Settings dialog where you can select the protocol to use during the demo and, for the TCP/IP server and the HTTP server, you can set the port to use.



Server TCP/IP - Connect vo-CE to the "Interface"

To connect vo-CE to the "Interface TCP/IP server", you must:

- 1) select TCP/IP protocol from the settings dialog
- 2) select your language from the list
- 3) press the start button
- 4) set vo-CE to connect to the server where vo-CE interface is running (set parameters REMOTE HOST IP and REMOTE PORT)
- 5) set Telnet emulator to connect to the same device on which vo-CE is running (note: the default local port for vo-CE is not 23 as in Telnet but 1234)

At the top of the server area you can see two windows. The left one shows the commands that can be sent to the client. They correspond to the commands stored in the "Command" table. For each of these you can view information by pressing the corresponding icon . To send the command you need to click the command or the appropriate icon , and once the parameter is inserted (if required), press the submit button.

The right window displays the available languages. You can change the language at any time during the simulation.

The window in the bottom shows the communications between the server and the client.

Please refer to the **Demo Guide** for more information.

Server RDP - Connect vo-CE to the "Interface"

To connect vo-CE to the "Interface RDP server", you must:

- 1) select RDP protocol from the Settings dialog
- 2) select your language from the list
- 3) press the start button (a small form will appear, it is optimized for devices with small screen)
- 4) configure vo-CE on the device to use the RDP and set the Run Asr At Startup parameter
- 5) connect the device to the PC with vo-CE Tools running using the Remote Desktop Application

Please refer to the **Demo Guide** for more information.

Server HTTP - Connect vo-CE to the "Interface"

To connect vo-CE to the "Interface HTTP server", you must:

- 1) select HTTP protocol from the settings dialog
- 2) select your language from the list
- 3) press the start button
- 4) configure vo-CE on the device to use the HTTP protocol and set the set parameters REMOTE HOST IP to the IP address of the PC where vo-CE Tools is running, REMOTE PORT to the port chosen (8080 by default) and LOCAL PORT
- 5) connect the browser of the device to the address `http://127.0.0.1:<LOCAL_PORT>`

Please refer to the **Demo Guide** for more information.

Run Telnet

Press "Run Telnet" to be connected connect to the determined port of the local machine where vo-CE Interface is running. This corresponds to the following "telnet 127.0.0.1 24" command line from the command prompt where 24 is the local port previously set using the "settings" button:

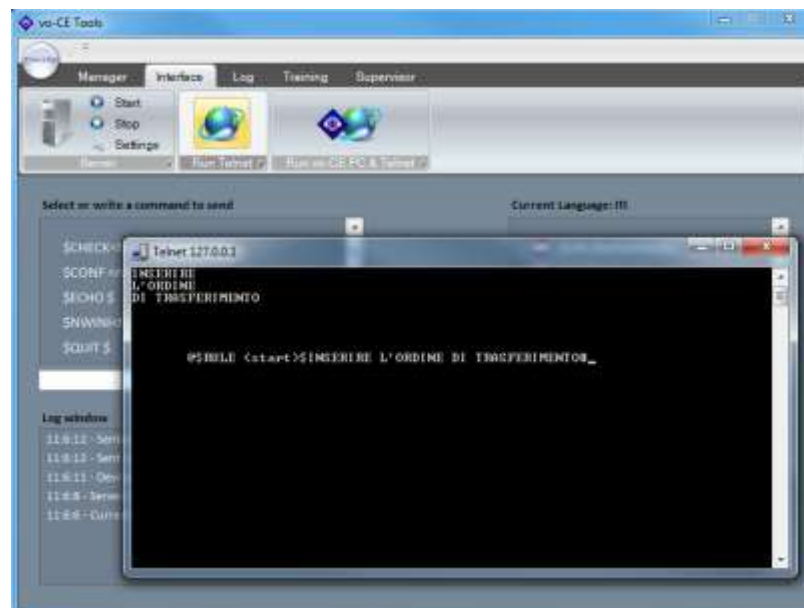

Without vo-CE software, all picking orders together with the vocal strings are shown in the DOS Telnet session. When the connection between the Telnet emulator and the WMS is filtered by vo-CE, you don't see the vocal strings on the screen of the mobile device, because they are inside vo-CE TAGS and so they the software application transforms them in speech output.

Run vo-CE PC & Telnet

Pressing "Run vo-CE PC & Telnet" will start the telenet session and, if installed on your PC, it will start vo-CE PC version.

4.4 LOG

In this section you can analyze a log file recorded by vo-CE. You can also analyze the log files of an operator in real time while he is working or save it directly to disk.

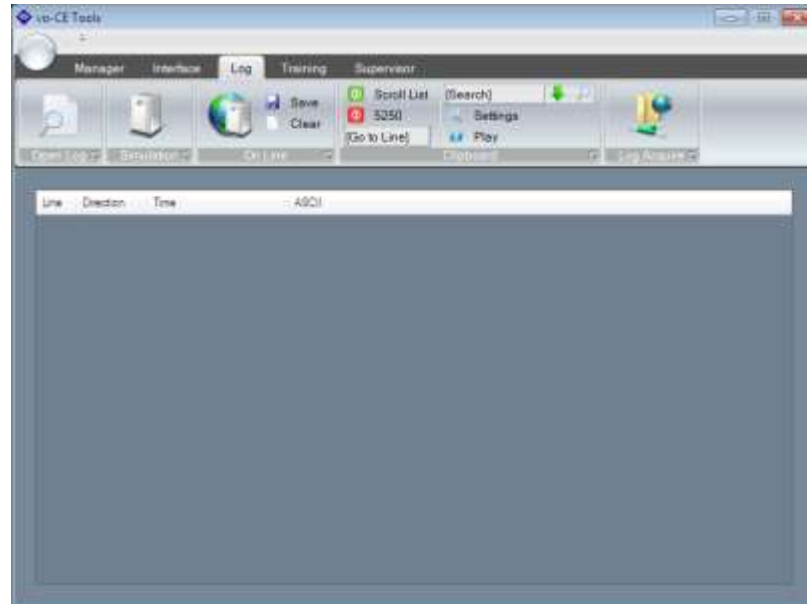

The "Simulation" and "On Line" subsections are two servers that work separately from each other. They can't work together as the activation of one leads to the shutdown of the other. The first one is a server that listens and waits for a connection from the device, whereas the second one is vo-CE Tools that starts a connection with the device.

Both can be configured by pressing “Settings” in the “Clipboard” subsection. “Local Port” represents the port to which the “Simulation” server listens, “Remote IP” and “Remote Port” represent the IP address and the port to which the “On Line” server should connect.



Open Log

Clicking the “Open Log” you can choose the file you want to have a look at. If the file has been recorded with AS400, you need to enable the “5250” icon in the “Clipboard” before opening the file.

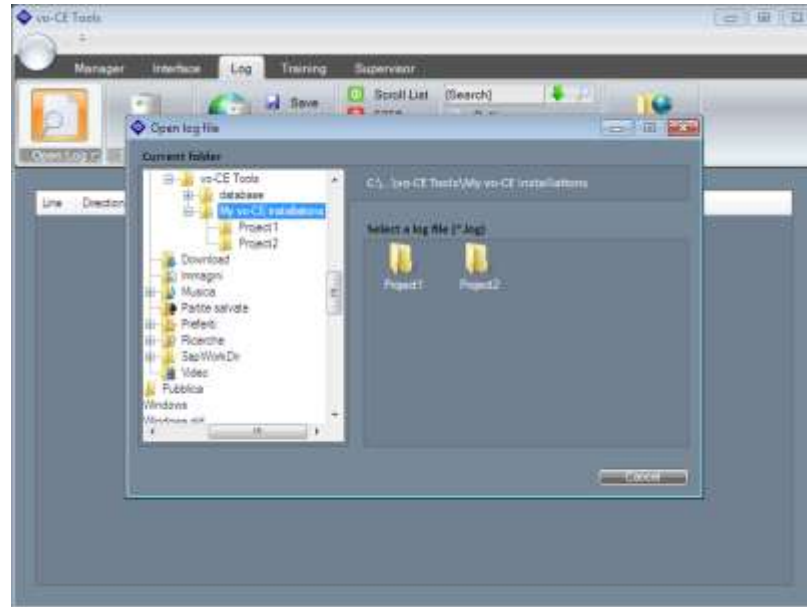

Once you open the file, you can go to a desired line or search for a particular word by their respective text fields in the “Clipboard” subsection.

Simulation

This model allows to send commands of the log file from the server to a device, thus simulating the activity that has been previously carried out with a possibility to observe the operations of the device. Once you open the log file, click the "Simulation". When the terminal connects to the "Interface" the connection is established. To send messages to the device, press the button "Play"  in the "Clipboard" subsection. It will automatically find the first line of the log file generated by the server and sent the command to the device. To move forward you should simply press the "Play" button and the cursor will automatically go to the next server row; you can also search and select it with the mouse.

Closing the client or clicking the "Simulation", the server stops listening. Pressing again the "Simulation" button the server goes on listening. The "On Line" server is deactivated.



Listening



Connected



Disconnected

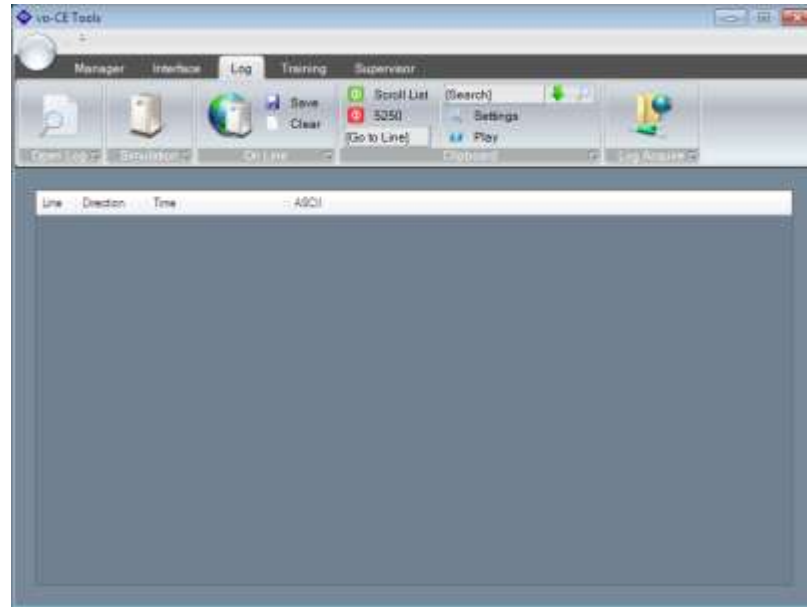

On Line

Pressing "On Line" button vo-CE Tools will try to establish a connection with the device shown in the "Settings".



If the parameter "TCPLOG" in vo-CE.ini of the device is active and therefore different from 0, vo-CE will accept the connection and you will see in real time the log of the operator's activity in the log window of vo-CE Tools.



You can clear the window using the button "Clear"  in any moment, while the "Save"  button allows you to save all that is currently visible in the window.



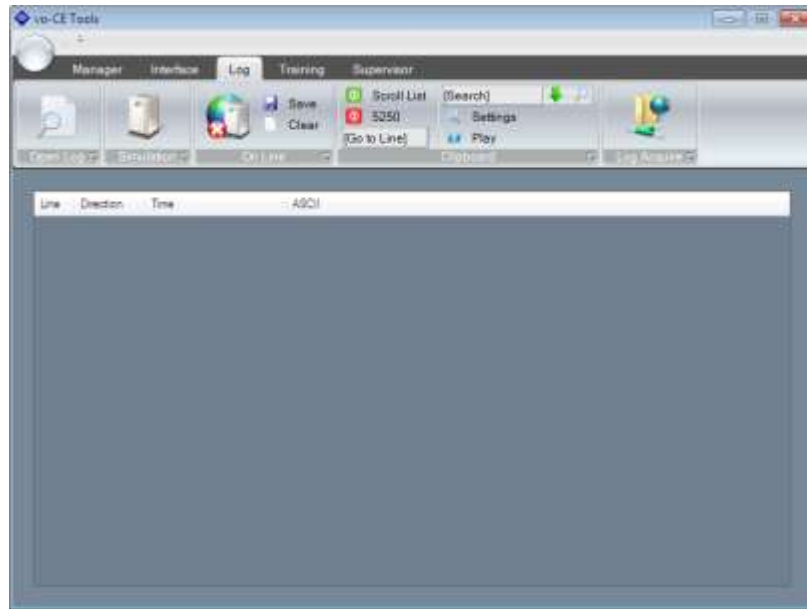

The disconnection can be performed on the client side or simply pressing the button "On Line".

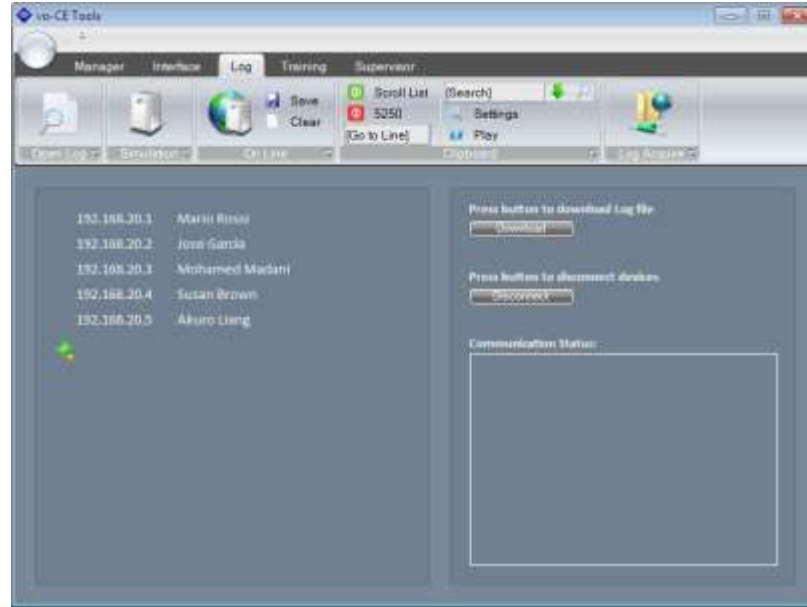

Log Acquire

In the "Log Acquire" section you have a database with the IP addresses of the terminals in operation and a short description.



Obviously you can add new items or remove them pressing the "New"  or "Delete"  icons respectively. When the desired terminal has been selected through the "Mark/Clear" icon  or pressing "Select All/Deselect All"  in case you want to select all items, you can press the button "Download" to start saving the log file containing the information on the activity that the operator is doing at that moment. To stop the download you need to simply press the "Disconnect" button. The log file will be store at the following path:

<Document Folder>\vo-CE Tools\My vo-CE installations\Log\deviceIPAddress\day-month-year

in this format:

deviceIPAddress-DayMonthYear-hHourmMinute.log

4.5 TRAINING

You can determine the various words that you want to train with the help of two sections: "Profile Management" and "Server".

Profile Management

First of all you have to create a profile for the current project. Once the file BNF, the word (that is present in the selected file) which must be repeated and the number of iteration is selected, click "Save Profile" to save the project profile.

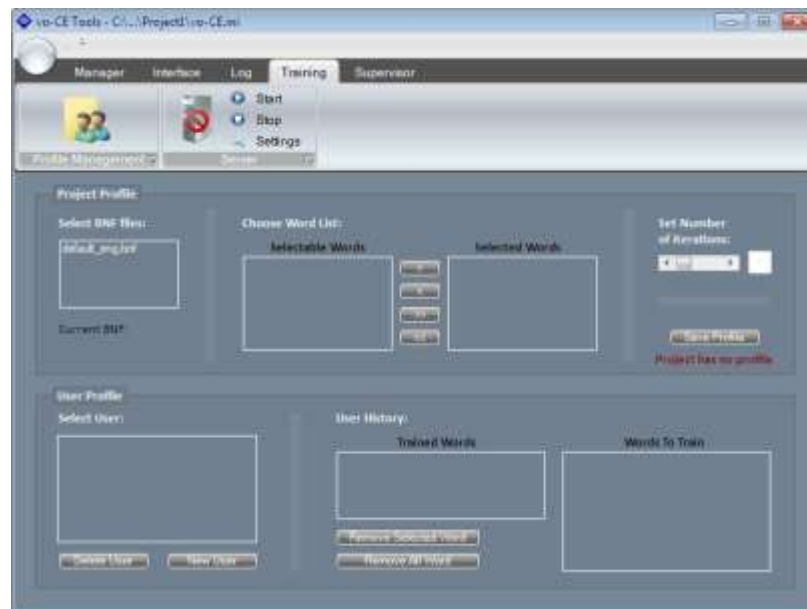

Now you can define a user profile. Clicking the "New User" button, you can define a user ID with his name and surname. Obviously, pressing "Delete User" allows a user to remove the unwanted user profile. In the "User History" section you can see the words that must be trained and those already learned.

Server

This section simulates a server that allows you to simulate the communication between the server and vo-CE to perform the training. The server will listen to the port specified by the "Settings" button.

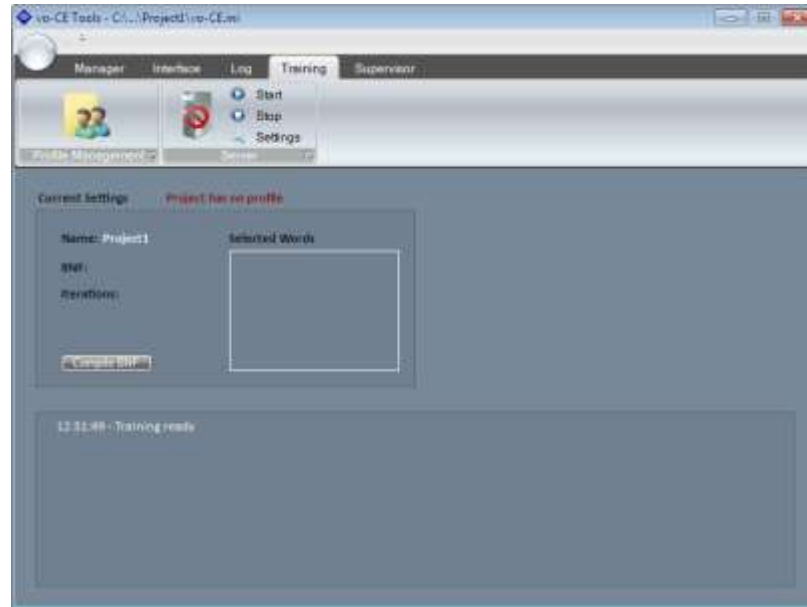





4.5 SUPERVISOR

In this section you can send messages to the operator who is performing his task. You also have the option to save the voice samples in order to evaluate the input signal given to vo-CE. To use the Supervisor, the "control" parameter in vo-CE.ini file has to be set to 1 and the terminal has to be connected to the server.

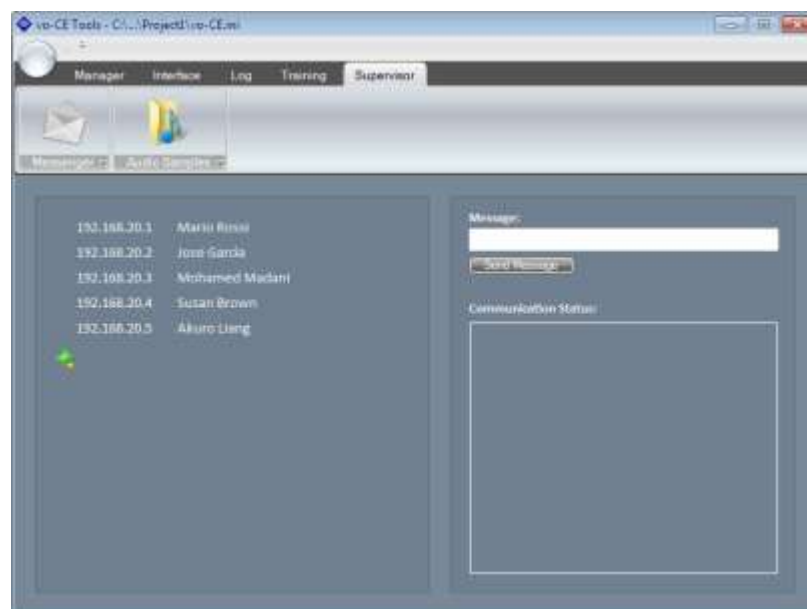
Messenger

In this subsection you do have a database with the IP addresses of terminals in operation and a short description.



You can add new items or remove them pressing the "New"  or "Delete"  icons respectively. When the desired terminal is selected with the icon "Mark/Clear"  or pressing "Select All/ Deselect All"  in case you want to select all terminals, you can press the "Send Message" button and the message contained in the text field will be sent to the selected terminals.

Audio Samples

In this section, the same IP addresses illustrated in the previous section are available. As you can see from the screenshot below, you can send a special command to vo-CE to save the audio file containing the words spoken by the operator on the device.

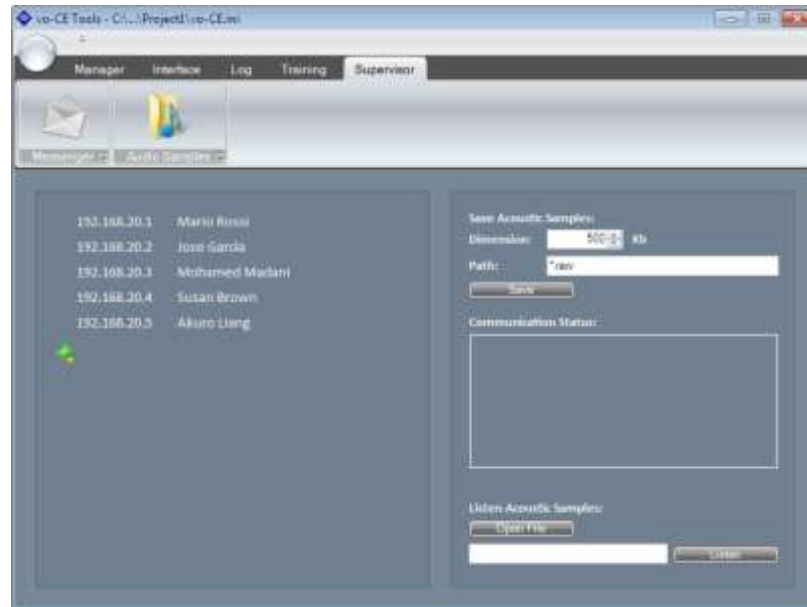

The field "Dimension" represents the maximum size (Kb) of the file. "Path" is the path of the terminal where the file should be saved. Once you press the "Save" button, the recording will stop at the next press of the button or when the file reaches the selected size. To listen to the generated file you should simply transfer the file from the device to your PC. Once the file is selected, click the "Open File" button and play the file pressing the "Listen" button. Clicking that file will not only make it play, but will create a "wav" file, which is more convenient to be used, in the same folder.

A ESCAPES SEQUENCES STRINGS.

<ESC> is the TTSESC character (vo-CE.ini parameter)

Sequence	Description	Range	Def.	Break
<ESC>"	Put the sentence accent			No
<ESC>\pause=n\ <ESC>Mn	Insert a pause Set the read mode	n = 1 ... 2^32-1 n = 0 ... 3: 0 = character-by-character 1 = word-by-word 2 = sentence-by-sentence 3 = line-by-line	2	No Yes
<ESC>\rate=n\ <ESC>\rate_wpm=n\ <ESC>\tn=s\ <ESC>\rate_wpm=n\ <ESC>\tn=s\ <ESC>\rate_wpm=n\ <ESC>\tn=s	Set the speech rate level Set the speech rate in words per minute Guide text normalization	n = 0 ... 100: 10 = slow 100 = fast n = 0 ... 1000: s = string: address, spell, normal	50	No No

B SERVER SIDE COMMANDS.

General syntax

Server can temporarily substitute the settings for vo-CE with the escapes sequences strings, but in order to make a definitive changes, server commands must be used.

Server commands syntactic is

@\$KEYWORD parameters\$...text to speech ...#

The "text to speech" is optional., vo-CE adds a default text ("OK"), if it misses, in the Grammar Switching command only.

A KEYWORD must be made of 5 characters . Use blanks to complete it if it is shorter.

NOTE: No text to speech can be inserted before a Server Command!

@I'm trying \$VOLUM 80\$ to use server commands# **ERROR!**

@\$VOLUM 80\$ I'm trying to use server commands# **OK**

Volume setting command:

Syntactic: \$VOLUMx\$

It changes the speaking volume.

The parameter is an integer from 0 to 100 that indicates the volume's value (0: mute 100: highest volume).

@I'm speaking with the default volume#

@\$VOLUM 100\$ Now I'm speaking with the highest volume#

@This phrase has the same volume of the second#

vo-CE will say the first phrase normally and the second and third ones with an higher volume.

Rate setting command:

Syntactic: \$RATE x\$

Changes the speaking rate level.

The parameter is an integer from 0 to 100 that indicates the rate.

As for VOLUM, vo-CE changes the value and after that says the text:

@I'm speaking with the default velocity#

@\$RATE 100\$Now I'm speaking fastest I can!#

@This phrase has the same velocity of the second#

vo-CE will say the first phrase normally and the second and third ones faster.

Start to recognize commands:

Syntactic: \$START\$

vo-CE enables the ASR engine. It will be disabled either when vo-CE receives the \$STOP\$ command or during the TTS process.

Stop to recognize commands:

Syntactic : \$STOP\$

vo-CE disables the ASR engine. It will be enabled when vo-CE receives the \$START\$ command. This command may be useful for the server if it you need to stop the voice session and perform a different activity:

@Perform a picking operation#

[...]

@\$STOP \$Now perform an order confirm operation without using vo-CE#

[...]

@\$START\$Well done! Restart the picking operation#

Grammar switching:

Syntactic: \$FILE grm_name.grm\$

vo-CE changes the grammar used. The parameter is the grammar filename. vo-CE will look for this file in its starting path. If it can't find it in that folder, it will ask for it on the FTP site (see "Change setting for vo-CE" for more details about FTP sites).

After this command the new grammar will be loaded. This command may be useful for associating grammars to different activities (one for the picking, one for the inventory...) and to load the right one when user switches from one activity to another.

Profile changing:

Syntactic: \$FILESprofile_name.spa\$

vo-CE changes the profile to use. The parameter is the profile filename.

vo-CE will look for this file in the "flash memory"\vo-CE path. If it can't find it in this folder, it will look for it on the FTP site (see "Change setting for vo-CE" for more details about FTP sites).

After this command, the new profile will be loaded.

vo-CE.ini file changing:

Syntactic: \$NWINlini_name.ini\$

vo-CE changes the .ini file. The value of this parameter is the .ini file name to use.

vo-CE will look for it in its starting folder.

NOTE: if you have installed different languages on the same device, use \$NWINlini_name.ini\$ server command to switch to a new .ini file which include a new language configuration.

Quit vo-CE:

Syntactic: \$QUIT \$

To close vo-CE. No value is required to execute this server command.

Confidence threshold changing:

Syntactic: \$CONF 4500\$

To modify the confidence threshold.

Send a message without modifying the repeat string

Syntactic: \$ECHO \$[...]

To send a message to the operator without overwriting the last assignment received from the WMS. Define a value for this command according to the message text.

When the operator has received the message, he can listen to the last assignment again.

Check command

CHECK – syntax \$CHECK<value> | <type> | <error message> | <minor option> | <question>\$ vo-CE performs a local check, i.e. for the check digit, without sending the data to the server. To allow the recognition of the <value> perform at its best, vo-CE assigns a confidence boost to that value; the boost is determined by the BOOSTVALUE (default 1000) parameter.

- **<value>** value to check.
- **<type>** can be:
 - i. **0** – User must say EXACTLY the <value>. Parameters <minor option> and <question> are not necessary.
 - ii. **1** – User can say a number that is less or equal to the <value>, but if is less than the <value>, the User must confirm that number. vo-CE will say the <question>.
 - iii. **2** - User can say a number that is less or equal to the <value>,no confirmation is needed.

- <error message> – the message that will be returned by vo-CE, if the User says a wrong number.
- <minor option> can be:
 - i. **0** – asking a confirmation with the <question>; the User has to reply with Yes or No.
 - ii. **1** - asking a confirmation with the <question>; the User has to repeat the number that has been just said.
- <question> is the question asked by vo-CE when the <type> is 1 or 2.

Disable the Check

UNCHK – syntax \$UNCHK\$ disables the previous CHECK command.

Load a Regular Expression

REGEX – syntax \$REGEX<regular expression>\$ loads the given regular expression.

- <regular expression> is the regular expression that will be loaded by vo-CE (See chapter XXX).

Change a Regular Expression

REGEF – syntax \$REGEF<regular expression name>\$ loads a regex with the selected name.

- <regular expression name> is the name of the regular expression that will be activated; that regular expression must be saved in the vo-ce.ini file under the section [REGEX].

Activate a new syntactic rule.

Syntactic: @\$RULE <rule name>\$#

To switch from one rule to another. The value you can assign to this command is the rule name to enable.

Modifying a parameter in the vo-CE ini file:

Syntactic: \$SETPAname_parameter=value_parameter\$

It allows the execution of any parameter of the vo-CE. ini file, while vo-CE is working.

The changes to the values of the parameters are valid while vo-CE is working.

When it is started again, the value of the parameter will be the one specified in the vo-CE.ini file.

Training session:

Syntactic: \$TRAIBprofiletobeupdated|profile name| BNFname|number of repetitions|command |
command [n]\\$

Using this command it is possible to create a user profile for specific commands (command 1\
command [n]\...\).

The profile can be an update of an existing profile or a new one.

If you have to update an existing profile_ to _be_ updated profile, it needs to be replaced with the
profile name to update, otherwise you need to add the starting string |.

In all cases the string has to specify the name of the new profile (without showing the extension.SPA),
the vocabulary name (with the extension BNF), the number of repetitions for each command, a list of
commands separated by “\”.

The string always ends with a “\”.

REPEATING ALL THE PRONOUNCED NUMBERS

Syntactic: £SPELL\$

When this command is sent, the system will repeat all the numbers previously said to the operator.

C LICENSING SITE

Visit the vo-CE [licence site](#) to manage vo-CE licences.



Insert **User name** and **Password** and press Log in.



The Internet page shows you:

- Id: the Client's ID
- Cliente: the Client's name

Prodotto: the software product you are licensing

- DataAqusto: the date and the hour of license purchase
- Num. Licenze: number of purchased licenses
- Rimaste: number of the licenses that haven't been used yet

Press "Select" to see the details of the used licenses or to release a new license.

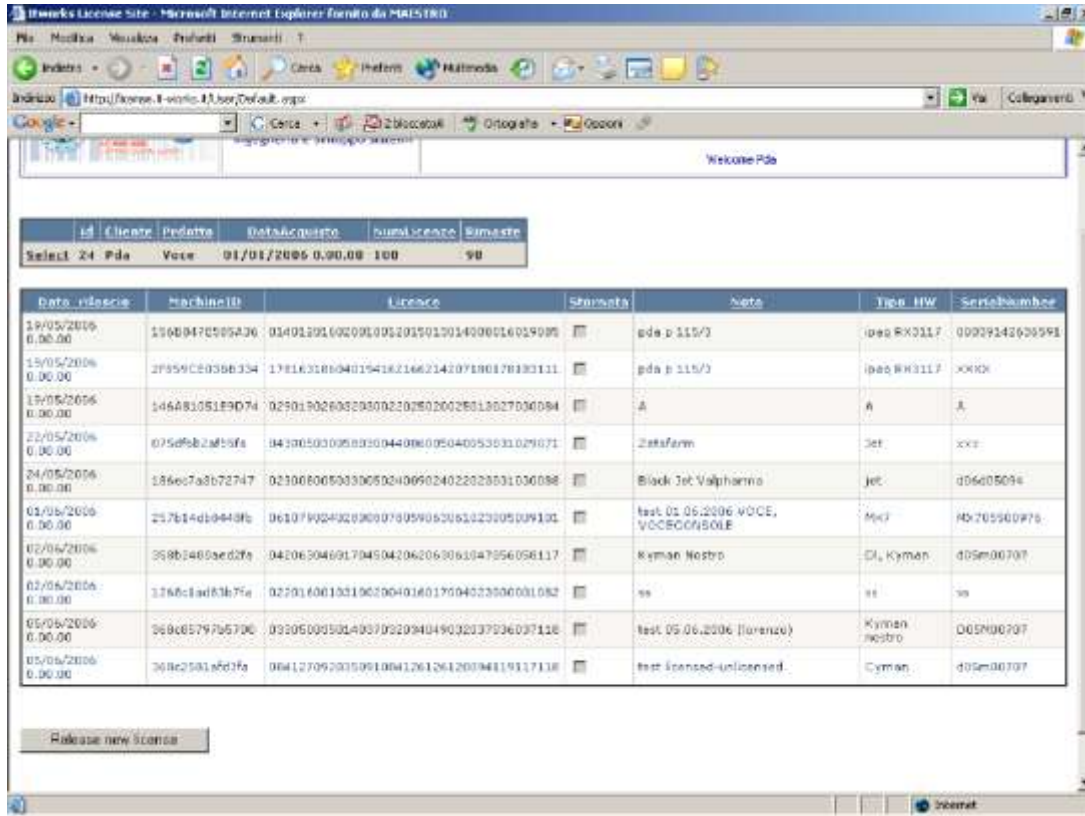

The page shows details of used licenses:

- Data rilascio: Release Date
- MachineID: the ID of the device on which the licensed vo-CE software is running
- License: the license key
- Stornata: a flag to show the cancellation of the license
- Nota: note
- Tipo HW: hardware model
- SerialNumber: the serial number of the device

Press "Release new license" to use one of the free purchased licenses.

Release a new license

MachineID:

Serial Number:

Tipo_HW:

Nota:

Data Rilascio:

License

The information to be inserted in this page includes:

- MachineID: the ID of the device on which you want to run licensed vo-CE
- SerialNumber: the serial number of the device
- Tipo_HW: the device hardware model
- Nota: if necessary, insert a note here
- Press "Crea Licenza" to create a new license.



The page shows the date of the release in the “Data Rilascio” field and your **new license** in the License field.

Press Back to return to the previous page.

D. VO-CE DOWNLOADING SITE

In the page that follows the login, there is a link to the download site on which it is possible to find all vo-CE files.

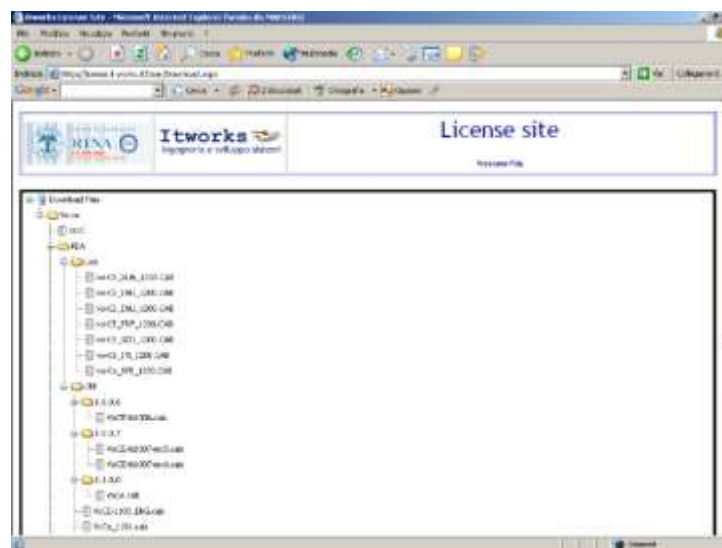
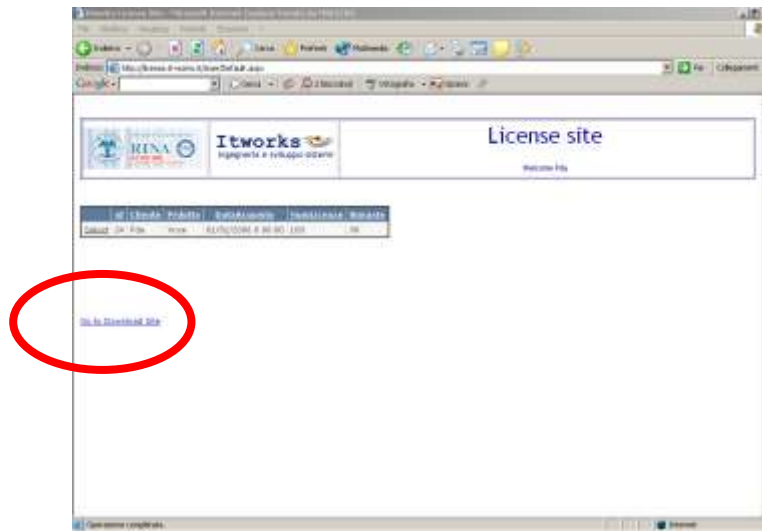

Exploring the tree it is possible to check all the released versions of vo-CE:

- PDA subdirectory: it contains products developed for the devices
- Win subdirectory: it contains products developed for Personal Computers
- DOC subdirectory: it contains the vo-CE documentation

For each product there is a folder called "Last" with the last versions and a folder called "Old" with the previous ones.

Click a product name to download it.

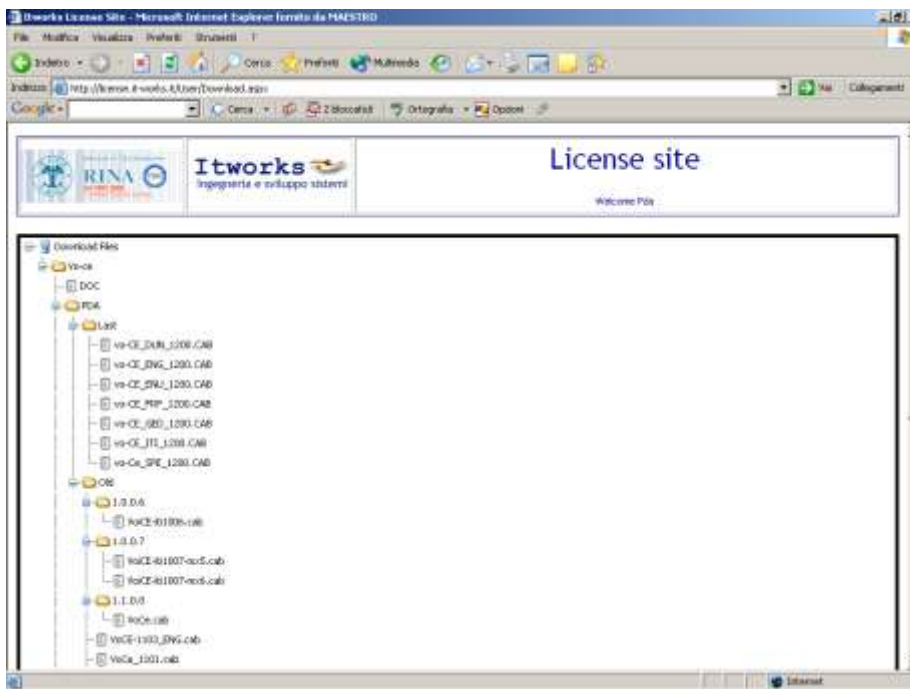

E GLOSSARY

The list below is the **glossary** of the manual.

Vocabulary: is a BNF file containing a list of licensed words and syntactic rules.

Grammar: is an LCF file. This file is used from vo-CE and fixes licensed words, syntactic rules and the way of speaking. This file is created from a vocabulary.

Dictionary: is a DCT file. This file is created by vo-CE once the training session is over, and it is used together with the profile (SPA file), to recognize different pronunciations.

DAT: is a file containing the language phonemes.

User Profile Project: With vo-CE manager it is possible to create a different profile for each operator. The information such as grammars, vocabularies, training data and so on, can be checked and corrected from a User Profile Project.

Special commands: are a useful set to create a sort of dynamic dialog between the operator and the vo-CE software. With their help it is possible to manage many operations: increase the volume, ask to repeat the last phrase, mute the microphone, etc.

Remapping words: Usually when vo-CE recognizes a command, it sends it to the keyboard buffer. However, it is possible to modify the recognized commands before sending them to the keyboard buffer.

The "remapping words" function may be used to add an *enter* or a *special key* (such as F1 or ESC), to ask for a confirmation of the recognized command, etc.

Escape string: is a special sequence of setting characters used by TTS to modify vo-CE parameters.

Regex: is a contraction of Regular Expression.

Rule: is a set of syntactic formalism in the vocabulary that determines what can be recognized by the engine.